

# iM3s Series

Vital Signs Monitor

Version 1.6

# User Manual

CE<sub>0123</sub>



# About this Manual

P/N: 01.54.458691

MPN: 01.54.458691016

Release Date: August 2023

© Copyright EDAN INSTRUMENTS, INC. 2020–2023. All rights reserved.

## Statement

This manual will help you understand the operation and maintenance of the product better. It is reminded that the product shall be used strictly complying with this manual. User's operation failing to comply with this manual may result in malfunction or accident for which EDAN INSTRUMENTS, INC. (hereinafter called EDAN) cannot be held liable.

EDAN owns the copyrights of this manual. Without prior written consent of EDAN, any materials contained in this manual shall not be photocopied, reproduced or translated into other languages.

Materials protected by the copyright law, including but not limited to confidential information such as technical information and patent information are contained in this manual, the user shall not disclose such information to any irrelevant third party.

The user shall understand that nothing in this manual grants him, expressly or implicitly, any right or license to use any of the intellectual properties of EDAN.

EDAN holds the rights to modify, update, and ultimately explain this manual.

## Responsibility of the Manufacturer

EDAN only considers itself responsible for any effect on safety, reliability and performance of the equipment if:

Assembly operations, extensions, re-adjustments, modifications or repairs are carried out by persons authorized by EDAN, and

The electrical installation of the relevant room complies with national standards, and

The instrument is used in accordance with the instructions for use.

## Terms Used in this Manual

This guide is designed to give key concepts on safety precautions.

### **WARNING**

A **WARNING** label advises against certain actions or situations that could result in personal injury or death.

### **CAUTION**

A **CAUTION** label advises against actions or situations that could damage equipment, produce inaccurate data, or invalidate a procedure.

### **NOTE**

A **NOTE** provides useful information regarding a function or a procedure.

# Table of Contents

<b>Chapter 1 Intended Use and Safety Guidance</b> .....	<b>1</b>
1.1 Intended Purpose .....	1
1.2 Intended Use/Indications for Use .....	1
1.3 Safety Guidance .....	1
1.4 Symbols .....	8
1.5 Contraindication .....	11
<b>Chapter 2 Basic Operation</b> .....	<b>12</b>
2.1 System Components .....	12
2.1.1 Host (Monitor) .....	13
2.1.2 CS-04 Charger Stand .....	15
2.1.3 CS-05 Extended Stand .....	16
2.2 Operating and Navigating .....	17
2.3 Work Mode .....	20
2.4 Measure View .....	20
2.5 Operating State .....	20
2.5.1 Standby Mode .....	20
2.5.2 Energy-Saving Mode .....	21
2.5.3 Demo Mode .....	21
2.6 Changing Monitor Settings .....	22
2.6.1 Adjusting Screen Brightness and Device Volume .....	22
2.6.2 Setting Languages .....	22
2.6.3 Password Management .....	22
2.7 Checking Your Monitor Information .....	22
2.8 Using the Barcode Scanner .....	23
<b>Chapter 3 Installation</b> .....	<b>24</b>
3.1 Initial Inspection .....	24
3.2 Connecting the Power Cable .....	24
3.3 Mounting the Monitor .....	24
3.3.1 Install the Monitor to Wall Mounting Bracket .....	25
3.4 Checking the Monitor .....	27
3.5 Connecting Sensor to Patient .....	28
3.6 Checking the Recorder .....	28
3.7 Setting Date and Time .....	28
3.8 Handing Over the Monitor .....	29

3.9 FCC Statement.....	29
3.10 FCC RF Radiation Exposure Statement.....	30
<b>Chapter 4 Operator Login.....</b>	<b>31</b>
<b>Chapter 5 Custom Parameters.....</b>	<b>32</b>
<b>Chapter 6 Ward Round Mode.....</b>	<b>33</b>
6.1 Creating New Patient.....	33
6.2 Editing Patient Information.....	34
6.3 Importing Patient.....	34
6.4 Refreshing Patient List.....	35
6.5 Selecting Patient for Measurement.....	35
6.6 Saving and Reviewing Data.....	36
6.7 Confirming Information.....	36
<b>Chapter 7 Spot-checking Mode.....</b>	<b>37</b>
7.1 Creating New Patient.....	37
7.2 Editing Patient Information.....	38
7.3 Saving and Reviewing Data.....	38
7.4 Confirming Information.....	39
<b>Chapter 8 Networking.....</b>	<b>40</b>
8.1 Cybersecurity Measures.....	40
8.1.1 Personal Information Safety.....	40
8.2 Wi-Fi.....	41
8.3 E-Link Function.....	43
8.4 HL7 Communication.....	43
8.5 ADT Query and Real-time Upload.....	44
<b>Chapter 9 Prompts.....</b>	<b>45</b>
<b>Chapter 10 Prompt Information.....</b>	<b>46</b>
10.1 Technical Prompt.....	46
10.2 Operation Prompt.....	51
<b>Chapter 11 User Interface.....</b>	<b>53</b>
11.1 Selecting Display Parameters.....	53
11.2 Default Configuration.....	53
<b>Chapter 12 Monitoring SpO<sub>2</sub>.....</b>	<b>54</b>
12.1 Overview.....	54
12.2 SpO <sub>2</sub> Safety Information.....	54
12.3 Measuring SpO <sub>2</sub> .....	55
12.4 Measurement Limitations.....	57

12.5 Assessing the Validity of a SpO <sub>2</sub> Reading .....	58
12.6 SpO <sub>2</sub> Prompt Delay .....	59
12.7 Perfusion Index (PI) .....	60
12.8 Setting Pitch Tone .....	60
12.9 Setting Sensitivity .....	60
12.10 SpO <sub>2</sub> Relevant Data for Reference .....	60
<b>Chapter 13 Monitoring PR .....</b>	<b>63</b>
13.1 Overview .....	63
13.2 PR Source .....	63
13.3 Setting PR Volume .....	63
<b>Chapter 14 Monitoring NIBP .....</b>	<b>64</b>
14.1 Overview .....	64
14.2 NIBP Safety Information .....	64
14.3 Measurement Limitations .....	66
14.4 Measurement Methods .....	67
14.5 Measurement Procedures .....	67
14.5.1 Operation Prompts .....	69
14.6 Resetting NIBP .....	70
14.7 Calibrating NIBP .....	70
14.8 Leakage Test .....	70
14.9 Setting Inflation Value .....	71
14.10 Manometer Mode .....	71
14.11 Cleaning Mode .....	72
<b>Chapter 15 Monitoring TEMP .....</b>	<b>73</b>
15.1 Quick TEMP with F3000 Module .....	73
15.1.1 Introduction .....	73
15.1.2 Probe Covers —Applying & Removing .....	75
15.1.3 Changing Isolation Chambers and Probes .....	75
15.1.4 Measuring Mode .....	76
15.1.5 Measuring Procedure .....	77
15.1.6 TEMP Setup for F3000 Module .....	79
15.2 Infrared TEMP with TAT Thermometer .....	80
15.3 TEMP Module via E-Link .....	80
<b>Chapter 16 Recording .....</b>	<b>81</b>
16.1 Starting and Stopping Recording .....	81
16.2 Recorder Operations and Status Messages .....	82

16.2.1 Record Paper Requirement.....	82
16.2.2 Proper Operation.....	82
16.2.3 Paper Out.....	82
16.2.4 Replacing Paper.....	82
16.2.5 Removing Paper Jam.....	83
<b>Chapter 17 Data Store .....</b>	<b>84</b>
17.1 Data Store.....	84
17.2 Formatting the Internal Storage Device.....	84
17.3 Viewing the Capacity of Internal Storage Device.....	84
17.4 Exporting Data to Removable Storage Device.....	84
<b>Chapter 18 Using Battery .....</b>	<b>85</b>
18.1 Battery Safety Information.....	85
18.2 Battery Charging Indicator.....	87
18.3 Battery Status on the Main Screen.....	87
18.4 Charging the Battery.....	88
18.5 Maintaining the Battery.....	88
18.6 Storing the Battery.....	88
18.7 Checking Battery Performance.....	89
18.8 Recycling the Battery.....	89
18.9 Replacing the Battery.....	89
<b>Chapter 19 Care and Cleaning.....</b>	<b>91</b>
19.1 Safety Instructions.....	91
19.2 General Points.....	91
19.3 Cleaning.....	92
19.3.1 Cleaning the Monitor.....	93
19.3.2 Cleaning the Reusable Accessories.....	94
19.4 Disinfection.....	96
19.4.1 Disinfecting the Monitor.....	97
19.4.2 Disinfecting the Reusable Accessories.....	98
19.5 Cleaning and Disinfecting Other Accessories.....	99
19.6 After Reprocessing.....	99
19.7 Storage and Transport.....	100
<b>Chapter 20 Maintenance .....</b>	<b>101</b>
20.1 Inspecting.....	101
20.2 Maintenance Task and Test Schedule.....	102
<b>Chapter 21 Warranty and Service.....</b>	<b>103</b>

21.1 Warranty .....	103
21.2 Contact Information .....	103
<b>Chapter 22 Accessories .....</b>	<b>104</b>
22.1 SpO <sub>2</sub> Accessories .....	104
22.2 NIBP Accessories .....	105
22.3 TEMP Accessories .....	106
22.4 Other Accessories .....	107
<b>A Product Specification .....</b>	<b>108</b>
A.1 Classification .....	108
A.2 Physical Specifications .....	108
A.2.1 Size and Weight .....	108
A.2.2 Function Configuration .....	109
A.2.3 Environment Specification .....	110
A.2.4 Display .....	111
A.2.5 Battery Specification .....	111
A.3 NIBP .....	112
A.4 SpO <sub>2</sub> .....	114
A.5 PR .....	115
A.6 TEMP .....	115
A.7 Wi-Fi .....	116
A.8 E-Link .....	117
A.9 USB Interface .....	117
<b>B EMC Information .....</b>	<b>118</b>
B.1 Electromagnetic Emissions .....	118
B.2 Electromagnetic Immunity .....	119
B.3 Electromagnetic Immunity .....	121
B.4 Recommended Separation Distances .....	126
<b>C Default Settings .....</b>	<b>127</b>
C.1 Patient Information Default Settings .....	127
C.2 Operator Information Default Settings .....	127
C.3 SpO <sub>2</sub> Default Settings .....	128
C.4 PR Default Settings .....	128
C.5 NIBP Default Settings .....	128
C.6 TEMP Default Settings .....	128
<b>D Abbreviations .....</b>	<b>129</b>



# Chapter 1 Intended Use and Safety Guidance

## 1.1 Intended Purpose

The product is intended for monitoring, displaying, reviewing, storing, alarming, and transferring of multiple physiological parameters.

## 1.2 Intended Use/Indications for Use

The device is intended to be used for measuring, storing, and reviewing of, and to generate prompts for, multiple physiological parameters of adults and pediatrics (including neonates). The device is intended for use by trained healthcare professionals in hospital environments.

Parameters include: NIBP, SpO<sub>2</sub>, PR (pulse rate), TEMP.

The F3000 Quick TEMP module is not intended for neonates.

The device is not intended for MRI environments.

## 1.3 Safety Guidance

Federal (U.S.) law restricts this device to sale by or on the order of a physician.

---

---

### **WARNING**

- 1 To ensure that the monitor works properly, please read the user manual and follow the steps before using the monitor.**
  - 2 Before using the device, the equipment, patient cable and sensors etc. should be checked. Replacement should be taken if there is any evident defect or signs of aging which may impair the safety or performance.**
  - 3 Medical technical equipment such as these monitor/monitoring systems must only be used by persons who have received adequate training in the use of such equipment and who are capable of applying it properly.**
  - 4 SHOCK HAZARD-To avoid the RISK of electric shock, this equipment must only be connected to a SUPPLY MAINS with protective earth. Never adapt the three-prong plug from the monitor to fit a two-slot outlet.**
- 
-

---

---

**WARNING**

---

---

- 5 Devices connecting with monitor should be equipotential.**
  - 6 Extreme care must be exercised when applying medical electrical equipment. Many parts of the human/machine circuit are conductive, such as the patient, connectors, transducers. It is very important that these conductive parts do not come into contact with other grounded, conductive parts when connected to the isolated patient input of the device. Such contact would bridge the patient's isolation and cancel the protection provided by the isolated input. In particular, there must be no contact of the neutral electrode and ground.**
  - 7 EXPLOSION HAZARD-Do not use the device in a flammable atmosphere where concentrations of flammable anesthetics or other materials may occur.**
  - 8 Do not come into contact with the patient, table, or the monitor during defibrillation.**
  - 9 Magnetic and electrical fields are capable of interfering with the proper performance of the device. For this reason make sure that all external devices operated in the vicinity of the monitor comply with the relevant EMC requirements. X-ray equipment ,MRI devices, radio systems (cellular phones) and so forth, are a possible sources of interference as they may emit higher levels of electromagnetic radiation. Verify the performance of the system before use.**
  - 10 Route all cables carefully to avoid possible entanglement, apnea, or electrical interference. For the device mounted over the patient, sufficient precautionary measures should be taken to prevent it from falling on the patient.**
  - 11 Accessory equipment connected to the analog and digital interfaces must be certified according to the respective IEC/EN standards (e.g. IEC/EN 60950 for data processing equipment and IEC/EN 60601-1 for medical equipment). Furthermore all configurations shall comply with the valid version of the standard IEC/EN 60601-1. Therefore anybody, who connects additional equipment to the signal input or output connector to configure a medical system, must make sure that it complies with the requirements of the valid version of the system standard IEC/EN 60601-1. If in doubt, consult our technical service department or your local distributor.**
  - 12 If the accessory is accidentally disconnected, it shall be reconnected by a trained healthcare professional.**
- 
-

---

---

**WARNING**

---

---

- 13 Only patient cable and other accessories supplied by EDAN can be used. The performance and electric shock protection cannot be guaranteed, and the patient may be injured otherwise. Prior to use, check if the casing of a disposable accessory is intact. Do not use it if its casing is damaged.**
  - 14 When interfacing with other equipment, a test for leakage current must be performed by qualified biomedical engineering personnel before using with patients.**
  - 15 If several items of medical equipment are interconnected, pay attention to the sum of the leakage currents, otherwise it may cause shock hazard. Consult your service personnel.**
  - 16 Do not service or maintain the monitor or any accessory which is in use with the patient.**
  - 17 This equipment is not intended for home usage.**
  - 18 During working process, if the power supply is off and there is no battery for standby, the monitor will be off. Patient type will be restored to adult by default, and the monitor is in status with no patients. The settings configured by the user can be stored, and settings not configured by user keep no change. That is, the last settings used will be recovered when the power is restored.**
  - 19 The device and accessories are to be disposed of according to local regulations after their useful lives. Alternatively, they can be to the dealer or the manufacturer for recycling or proper disposal. Batteries are hazardous waste. Do NOT dispose them together with house-hold garbage. At the end of their life hand the batteries over to the applicable collection points for the recycling of waste batteries. For more detailed information about recycling of this product or battery, please contact your local Civic Office, or the shop where you purchased the product.**
  - 20 The packaging is to be disposed of according to local or hospital's regulations; otherwise, it may cause environmental contamination. Place the packaging at the place which is inaccessible to children.**
- 
-

---

---

**WARNING**

---

---

- 21** The appliance coupler or mains plug is used as isolation means from supply mains. Position the monitor in a location where the operator can easily access the disconnection device.
- 22** Assembly of the monitor and modifications during actual service life shall be evaluated based on the requirements of IEC60601-1.
- 23** Only recommended batteries can be used for the monitor.
- 24** Additional multiple socket-outlets or extension cords can't be connected to the system.
- 25** Only items that have been specified as part of the system or specified as being compatible with the system can be connected to the system.
- 26** The medical electrical equipment needs to be installed and put into service according to the EMC Information provided in this user manual.
- 27** The simultaneous use of a cardiac pacemaker or other electrical stimulators may cause safety hazard.
- 28** Operation of the equipment exceeding specified physiological signal or the operational specification may cause inaccurate results.
- 29** Connecting any accessory (such as external printer) or other device (such as the computer) to this monitor makes a medical system. In that case, additional safety measures should be taken during installation of the system, and the system shall provide:
- a) Within the patient environment, a level of safety comparable to that provided by medical electrical equipment complying with IEC/EN 60601-1, and
  - b) Outside the patient environment, the level of safety appropriate for non-medical electrical equipment complying with other IEC or ISO safety standards.
- 30** Portable and mobile RF communications equipment can affect medical electrical equipment; refer to the recommended separation distances provided in this user manual.
- 
-

---

---

**WARNING**

---

---

- 31 Using accessories other than those specified may result in increased electromagnetic emission or decreased electromagnetic immunity of the monitoring equipment.**
- 32 The monitor should not be used adjacent to or stacked with other equipment. If adjacent or stacked use is necessary, you must check that normal operation is possible in the necessary configuration before you start monitoring patients.**
- 33 Do not touch accessible parts of medical or non-medical electrical equipment in the patient environment and the patient simultaneously, such as USB connector or other signal input/output connectors.**
- 34 SHOCK HAZARD - Don't connect electrical equipment, which has not been supplied as a part of the system, to the multiple portable socket-outlet supplying the system.**
- 35 Clinical decision making based on the output of the device is left to the discretion of the provider.**
- 36 SHOCK HAZARD - Don't connect electrical equipment, which has been supplied as a part of the system, directly to the wall outlet when the non-medical equipment is intended to be supplied by a multiple portable socket-outlet with an isolation transformer.**
- 37 To protect the monitor from damage during defibrillation, for accurate measurement information and to protect against noise and other interference, use only accessories specified by EDAN.**
- 38 No modification of this equipment is allowed without authorization of the manufacturer. If this equipment is modified, appropriate inspection and testing must be conducted to ensure continued safe operation.**
- 39 Wireless LAN equipment contains an intentional RF radiator that has the potential of interfering with other medical equipment, including patient implanted devices. Be sure to perform the electromagnetic compatibility test before installation and any time new medical equipment is added to the Wireless LAN coverage area.**
- 
-

---

---

**WARNING**

- 40** The monitor is equipped with Wi-Fi to receive RF electromagnetic energy. Therefore, any other equipment complying with CISPR radiation requirements may also interfere with the wireless communication and make it interrupted.
  - 41** If the protective grounding (protective earth) system is doubtful, the monitor must be supplied by internal power only.
  - 42** Portable RF communications equipment (including peripherals such as antenna cables and external antennas) should be used no closer than 30 cm (12 inches) to any part of the monitor, including cables specified by the manufacturer. Otherwise, degradation of the performance of this equipment could result.
  - 43** Make sure networking function is used in a secure network environment.
  - 44** The monitor is intended for spot-checking only, not for continuous monitoring.
  - 45** Do not use the monitor in the presence of electrosurgery/HF (high frequency) equipment.
  - 46** Do not touch the screen with your fingertip during the host's startup, otherwise, it may result in the touch screen failure. Unplug the battery and restart the monitor to make the touch screen return to normal.
- 
- 

---

---

**CAUTION**

- 1** Electromagnetic Interference - Ensure that the environment in which the patient monitor is installed is not subject to any sources of strong electromagnetic interference, such as radio transmitters, mobile telephones, microwaves, etc.
  - 2** Keep the environment clean. Avoid vibration. Keep it far away from corrosive medicine, dust area, high temperature and humid environment.
  - 3** Do not immerse transducers in liquid. When using solutions, use sterile wipes to avoid pouring fluids directly on the transducer.
  - 4** Do not use autoclave or gas to sterilize the monitor, recorder or any accessories.
- 
-

---

---

**CAUTION**









- 5 The device and reusable accessories may be sent back to the manufacturer for recycling or proper disposal after their useful lives.**
  - 6 Disposable devices are intended for single use only. They should not be reused as performance could degrade or contamination could occur.**
  - 7 To ensure patient safety, use only parts and accessories manufactured or recommended by EDAN.**
  - 8 Before connecting the monitor to the AC power, make sure the voltage and the power frequency are consistent with the requirements indicated on the device label or in this user manual.**
  - 9 Protect the device against mechanical damage resulting from falls, impacts, and vibration.**
  - 10 Do not touch the touch screen with a sharp object.**
  - 11 A ventilated environment is required for monitor installation. Do not block up the ventilation grille at the back of the device.**
  - 12 The device must be connected to the ground to avoid signal interference.**
  - 13 To protect eyes from damage, don't look directly at supplementary light for long time.**
  - 14 Poor connection might be caused by frequently plugging and unplugging the power cord. Check the power cord regularly and replace it in time.**
  - 15 Ensure that the monitor is supplied with continuous electric power during operation from the main source power or batteries. Sudden power failure may cause failure to monitor parameters.**
- 
- 

**NOTE:**









- 1 Position the device in a location where the operator can easily see the screen and access the operating controls.**
- 2 The monitor can only be used on one patient at a time.**
- 3 If the monitor gets damp or liquid pours on the monitor, please contact the service personnel of EDAN.**















- 4 **This monitor is not a device for treatment purposes.**
- 5 **The pictures and interfaces in this manual are for reference only.**
- 6 **Regular preventive maintenance should be carried out every two years. You are responsible for any requirements specific to your country.**
- 7 **When there's measurement beyond range, invalid measurement or no measurement value, it will display -?-.**
- 8 **In normal use, the operator shall stand in front of the monitor.**
- 9 **The materials with which the patient or any other person can come into contact conform to the standard of EN ISO 10993-1.**

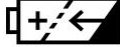



## 1.4 Symbols

1		DEFIBRILLATION-PROOF TYPE CF APPLIED PART
2		TYPE BF APPLIED PART (Applicable to CS-05 Extended Stand, IR20b TEMP)
3		Equipotentiality (Applicable to CS-05 Extended Stand)
4		Caution
5		MR Unsafe - Keep away from magnetic resonance imaging (MRI) equipment
6		Operating instructions
7		Refer to instruction manual/booklet (Background: Blue; Symbol: White)
8		Warning (Background: Yellow; Symbol & outline: black)
9		CE marking



10		General symbol for recovery/recyclable
11		The products marked with this symbol apply to the European WEEE directive. This symbol indicates this equipment contains electrical or electronic components that must not be disposed of as unsorted municipal waste, but collected separately. Contact an authorized representative of the manufacturer for information for the decommissioning of your equipment.
12		Serial Number
13	P/N	Part Number
14	<b>IPX1</b>	Ingress Protection IPX1 (Protected against vertically falling water drops) (Applicable to the Stand)
15	<b>IP44</b>	Ingress Protection: IP44 (protected against splashing water and solid foreign objects $\geq 1.0$ mm diameter) (Applicable to the monitor)
16	 (Optional)	Non-ionizing electromagnetic radiation
17		AUTHORISED REPRESENTATIVE IN THE EUROPEAN COMMUNITY
18	<b>Rx Only</b>	Caution: Federal (U.S.) Law restricts this device to sale by or on the order of a physician.
19		Date of manufacture
20		MANUFACTURER
21		This way up
22		Fragile, handle with care

23		Keep dry
24		Stacking limit by number
25		Handle with care
26		Do not step on
27		Use-by date
28		Power Supply switch
29		USB (Universal Serial Bus) Connection (Applicable to CS-05 Extended Stand)
30		Chargeable battery
31		Battery check
32		Alternating current
33		Direct current
34		Data communication
35		Barcode scanning window
36		TEMP measurement (button)
37		AA battery
38		Anode for Battery

39		Cathode for Battery
40	<b>FCC ID</b>	Federal Communications Commission:  FCC ID: SMQIM3SEDAN
41	ETL CLASSIFIED  Intertek 4005997 (Optional)	CONFORMS TO AAMI STD ES60601-1, IEC STD 60601-1-6, IEC STD 80601-2-30, ISO STD 80601-2-56, ISO STD 80601-2-61  CERTIFIED TO CSA STD C22.2 NO. 60601-1, CSA STD C22.2 NO. 60601-1-6
42		Medical Device
43		Unique Device Identifier
44		Protective earth (ground)

**NOTE:**

**The user manual is printed in black and white.**

## 1.5 Contraindication

None known.

## Chapter 2 Basic Operation

This user manual describes all features and options. Your monitor may not have all of them; they are not all available in all geographies. What you see on the screen, how the menus appear and so forth, depend on the way it has been tailored for your hospital and may not be exactly as shown here.

iM3s series include iM3s, iM3As, iM3Bs and iHM3s.

You may frequently use the follow functions:

- ◆ SpO<sub>2</sub> monitoring (Refer to *Monitoring SpO<sub>2</sub>* for more information.)
- ◆ PR monitoring (Refer to *Monitoring PR* for more information.)
- ◆ NIBP monitoring (Refer to *Monitoring NIBP* for more information.)
- ◆ TEMP monitoring (Refer to *Monitoring TEMP* for more information.)

### 2.1 System Components



Host & Stand



Protection Cover for Host

---

#### **WARNING**

**To avoid infection, do not touch the protection cover with injured skin.**

---

### 2.1.1 Host (Monitor)

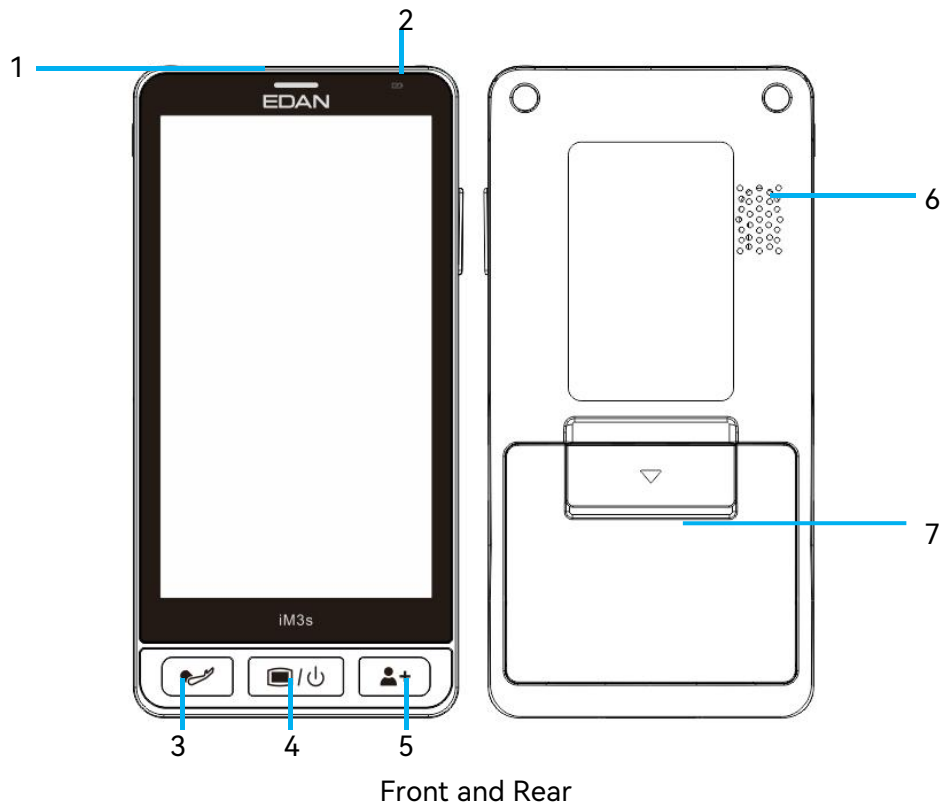

1	Power-on/Prompt /Standby Indicator	When starting up, the indicator flashes once in order of three colors; When prompt occurs, the indicator keeps lighting in blue. When Standby indicator is turned on, the indicator lights in blue in standby mode.
2	Charging Indicator	Lighting in yellow means charging; Lighting in green means full charge; Flashing in yellow means low battery; Indicator off in charging process means charging fault.
3	Start/stop NIBP Measurement	Press it to start or stop blood pressure measurement.
4	Power Switch/Main Menu	Keep pressing it to turn the monitor on/off; When the monitor is on, press it to return to the main interface.
5	Admit/Create New patient	Press it to admit/create new patient. Admitting or creating new patient will clear the data in main interface.

6	Speaker	For prompt sound, pulse sound and so forth.
7	Battery Door	For fixing or replacing the battery. Open or close battery door as arrow direction.

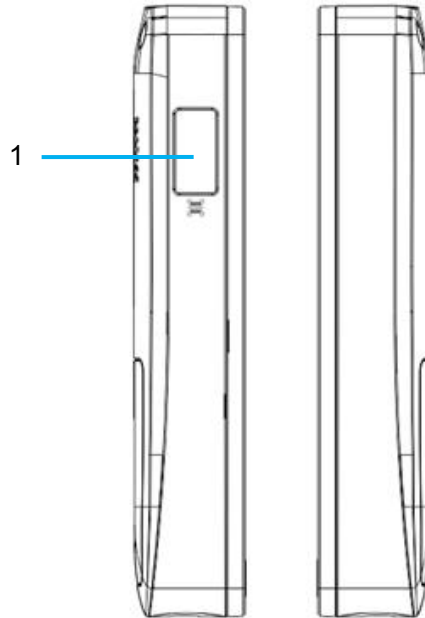

Left side and Right side

1	Barcode scanning window
---	-------------------------

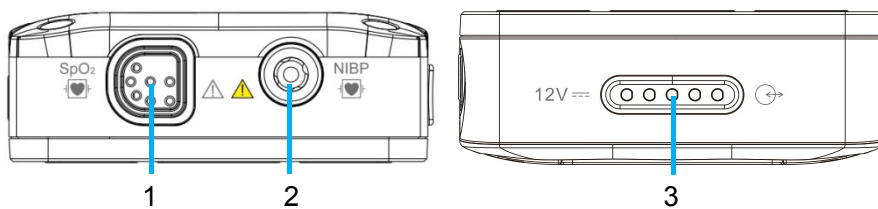

Top and Bottom

1	SpO <sub>2</sub> port: for connecting the parameter sensor
2	NIBP port: for connecting the parameter sensor
3	Charging or communication port: Used to connect the Stand for charging or connect the CS-05 for data communication.

### 2.1.2 CS-04 Charger Stand

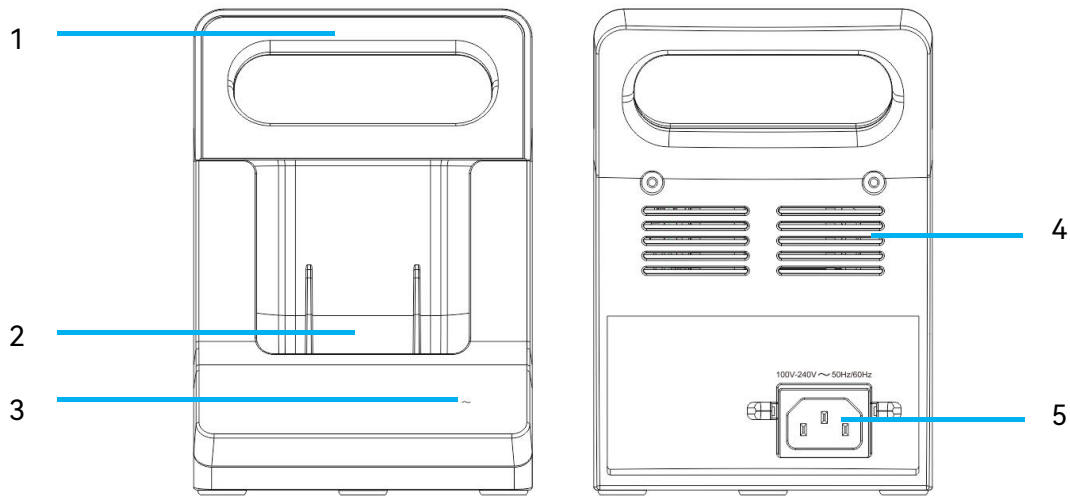

Front and Rear

1	Portable handle/Accessory collecting: for lifting or moving the monitor or collecting the accessories
2	Charging port between Host and Stand: Used to connect the Host for charging
3	AC power supply indicator On: AC power is connected; Off: AC power is not connected
4	Heat sink
5	AC power input: for connecting AC power cable

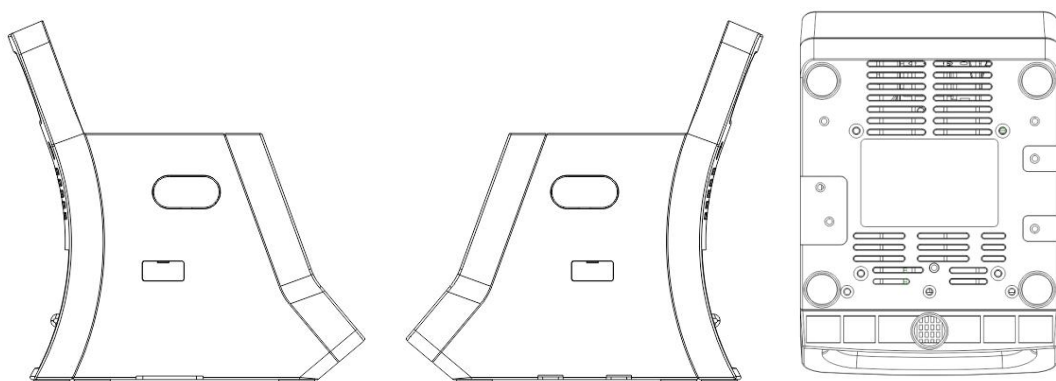

Left, Right, Bottom

Left, Right	Plug-in interface
Bottom	Heat sink

### 2.1.3 CS-05 Extended Stand

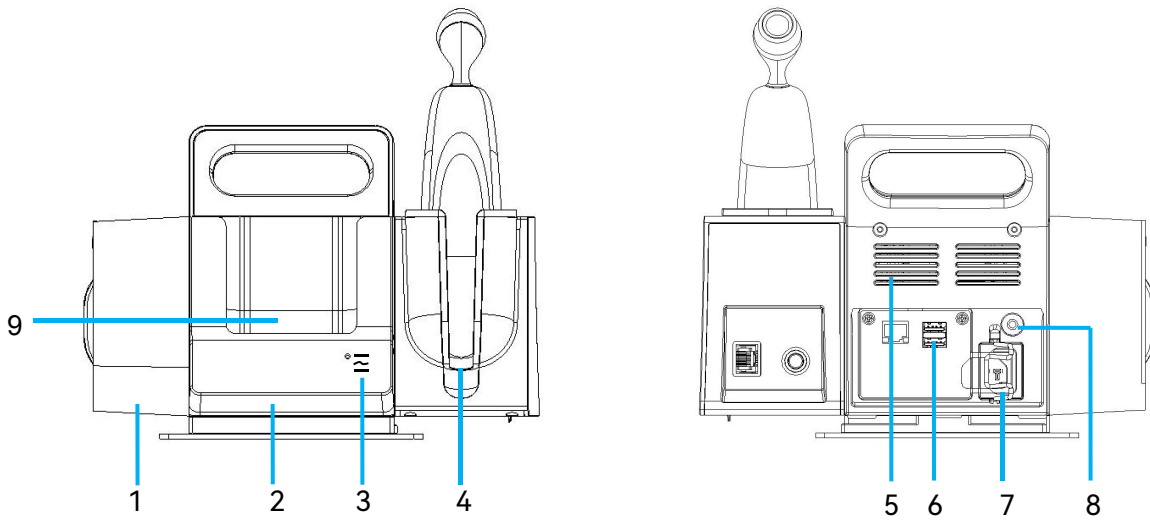

Front and Rear

1	Recorder: Used to print out
2	Extended Stand
3	<p>Indicator, from top to bottom:</p> <ul style="list-style-type: none"> <li>◆ Working indicator of the Stand</li> </ul> <p>Keeps lighting in green: connected with monitor and will respond to host monitor;</p> <p>Flashes in green: disconnected with monitor;</p> <p>Off: in Off status;</p> <ul style="list-style-type: none"> <li>◆ AC Power indicator of the Stand</li> </ul> <p>Keeps lighting in green: connected with AC power;</p> <p>Off: disconnected with AC power;</p> <ul style="list-style-type: none"> <li>◆ Battery Power indicator of the Stand</li> </ul> <p>Keeps lighting in green: battery full;</p> <p>Keeps lighting in yellow: in charging;</p> <p>Flashes in yellow: battery low;</p> <p>Off: no battery inserted or zero battery power or battery fault.</p>



4	Plug-in TEMP module, including TAT-5000S TEMP or F3000 TEMP. The TEMP module in the figure above is for reference only.
5	Heat sink
6	USB interface: supports USB 2.0 output. It connects approved USB devices, for example, USB flash disk. It is for software upgrade operated by service personnel of the manufacturer and for data export (such as export the review data to removable device).
7	AC power input: for connecting AC power cable
8	Equipotential grounding terminal. If the monitor is used together with other devices, connect this terminal to eliminate potential ground differences between devices.
9	Charging or communication port: Used to connect the Host for charging or data communication.











## 2.2 Operating and Navigating

Everything you need to operate the monitor is contained on its screen. Almost every element on the screen is interactive. Screen elements include measurement data, waveforms, screen keys, information fields and menus. The configurability of the monitor means that often you can access the same element in different ways. For example, you might be able to access an item through its on-screen setup menu, via a hard key, or via a shortcut key. The User Manual always describes how to access items via an on-screen menu. You may use whichever way you find most convenient.



Work mode	Date&Time, Icons
Prompts	
Patient Info.	Quick Admit (barcode scanning icon)
Parameters data (value&waveform)	
Custom parameters	
Filing time Operator Info.	Save
Shortcut keys	





Main Interface

Icons in main interface:

















	Wi-Fi		Send data through E-Link
	E-Link disconnected		Receive data through E-Link
	Prompts		Network server connected
	Network server disconnected		Battery power of the monitor
	USB flash disk inserted to CS-05 Extended Stand		Battery power of CS-05 Extended Stand

Shortcut keys:









	New patient (in Spot-checking mode)		Review
---	--	---	--------

	Operator (also called User)		Menu
	Select patient (in Ward Round mode)		Switch patient (in Ward Round mode)

Function icons

In ward round mode			
	New patient		Import patient based on the network query
	Set network query condition		Patients from network query
In ward round mode or spot-checking mode			
	Barcode scanning		Save
	Search		Delete
	More operations		Upload
	Export		Recording to print
	Switch to Chinese input keyboard		
Slide NIBP parameter area left to show the icons			
	Start or stop Manual measurement.		
	Start or stop Continual measurement.		
	Start or stop AVG measuring.		

Other icons

	Patient type: ADU		Patient type: PED		Patient type: NEO
	Measuring forehead TEMP			Measuring oral TEMP	
	Measuring axillary TEMP			Measuring rectal TEMP	
	Measuring ear TEMP				

### 2.3 Work Mode

The monitor supports two work modes: Ward Round and Spot-checking.

Ward Round mode is used for multiple patients’ parameter measurement and data management. Spot-checking mode is used for single patient measurement and data management. Refer to specific chapter for details of these modes.

Click **Menu > Mode** to choose **Spot-checking** or **Ward Round**, click  to save the operation. The selected working mode will be displayed in upper left area.

**NOTE:**

**The history data in each mode can be viewed only in corresponding mode.**

### 2.4 Measure View

The monitor supports two measure views: **Simple mode** and **Normal mode**. In Simple mode, the monitor only displays parameter name, parameter value, parameter unit and measurement site. The default setting is **Simple Mode**. If a detailed interface is required, select **Menu > User Maintain > Measure View > Normal**.

### 2.5 Operating State

#### 2.5.1 Standby Mode

The following way can be used to enter into standby mode.

Automatic standby: click **Menu > Auto Standby >** choose **1 min, 2 min, 5 min, 10 min, 30 min, or Never**. The default setting of iM3s is 1 min. The default setting of iHM3s is 2 min. The default setting of iM3As is 5 min. The default setting of iM3Bs is 10 min. If there is no measurement, prompt and operation in preset time, the monitor will enter standby mode automatically. User can also turn on or off the **Standby Indicator**.

■ In standby mode:

1. The screen is off, and monitor stops measuring. The monitoring data before entering standby will be stored.
2. The monitor won't respond to any prompts, except the prompt of Battery Low.
3. The ongoing transmission or print task will be continuously completed.

■ The monitor exits standby mode in any of the conditions:

1. The user clicks any hardkey.
2. The prompt of Battery Low occurs.

After exiting standby mode, the monitor resumes monitoring, including parameter monitoring, storage and prompt.

**NOTE: After placing the host into the Stand and if there is no operation within 10 minutes (no screen touching and key pressing, NIBP and TEMP are not measured, no battery low prompt), the monitor will enter standby mode.**

## 2.5.2 Energy-Saving Mode

If there is no user operation within 1 minute (such as press the button, touch the screen), the device will automatically enter the energy saving mode.

In energy saving mode, the device performs normal measurement and the screen is displayed with the lowest brightness. The user clicks the screen or presses any key to exit energy saving, and the screen will restore its previous brightness.

## 2.5.3 Demo Mode

Select **Menu > Demo Mode**, then input password **3045** to enter or exit the mode.

After exiting, the monitor will retain the settings modified in the demo state.

---

### **WARNING**

**Demo Mode is for demonstration purposes only. You must not change into Demo Mode during monitoring.**

---

## 2.6 Changing Monitor Settings

### 2.6.1 Adjusting Screen Brightness and Device Volume

Select **Menu > Volume&Brightness**, adjust the **Key Volume**, **Prompt Volume** or **Brightness**.

**NOTE: When the prompt volume is switched off, the monitor won't give prompt sound even if a prompt occurs. In order to avoid endangering the patient safety, the user should use this function cautiously.**

### 2.6.2 Setting Languages

Select **Menu > User Maintain > Language** to choose desired language, click  to make the setting effective.

### 2.6.3 Password Management

1. Modifying User Maintain password: Access **Menu > User Maintain > Modify User Password**, then modify according the prompts > click icon  to confirm. If password is forgotten, please contact the service personnel.

**NOTE: For safety consideration, please change the password periodically, and a combination of words and numbers is recommended.**

2. Login password setting: Access **Menu > User Maintain > Auto Login**. When it is enabled, the monitor can directly enter the normal working interface after start-up; when it is disabled, the password is required to enter the normal working interface after start-up. User can **Modify Login Password** (default is **1234**, and the password should only be fixed as 4 digits).

## 2.7 Checking Your Monitor Information

Select **Menu > About** to view monitor information, such as device name, network type and network server address.

Access **Menu > User Maintain**, then user can set **Device Name**.

## 2.8 Using the Barcode Scanner

### 1. Barcode setting for user (namely Operator)

Select **Menu > User Maintain > Operator Barcode** to set the barcode of operator's **Last Name, First Name** and **ID**. Click icon  to confirm.

### 2. Barcode setting for patient

Select **Menu > User Maintain > Patient Barcode** to set the barcode of patient's **Last Name, First Name, MRN, Gender, Birth Year, Birth Month** and **Birth Day**. Click icon  to confirm.

**NOTE: The start and end code should be set before using scanner, otherwise the barcode can't be recognized normally. After setting start and end code, user should also set male code and female code to distinguish the gender.**

## Chapter 3 Installation

### NOTE:

**The monitor installations and settings must be configured by the authorized hospital personnel.**

### 3.1 Initial Inspection

Before unpacking, check the packaging and ensure that there are no signs of mishandling or damage. If the shipping cartons are damaged, contact the carrier for compensation and package them again.

Open the package carefully and remove the monitor and accessories. Check that the contents are complete and that the correct options and accessories have been delivered.

If you have any question, please contact your local supplier.

### 3.2 Connecting the Power Cable

For Stand part, connection procedure of the AC power line is listed below:

- 1 Make sure the AC power supply complies with the following specifications: 100 V-240 V, 50 Hz/60 Hz.
- 2 Connect the power cord provided with the monitor. Connect the power cord to connector of the Stand part. Connect the other end of the power cord to a grounded power outlet.

### NOTE:

- 1 **Connect the power cable to the socket specialized for hospital use.**
- 2 **Only use the power cable supplied by EDAN.**

### 3.3 Mounting the Monitor

If all situations are normal, please place the monitor on a flat, level surface, mount it on a wall or install it on a trolley. About how to install the trolley for the monitor, please refer to *Trolley Installation Guide*.



**WARNING**

- 1 The safe loads of the trolley are 11 kg. Exceeding the safe load may cause the device to fall.**
- 2 The wall mounting bracket can be fixed only on a concrete wall. Otherwise, a trolley is required.**
- 3 If you need to install the wall mounting bracket again, drill new holes, replace screws and plastic expansion pipes.**

### 3.3.1 Install the Monitor to Wall Mounting Bracket



Installing the wall mounting bracket

1. Collate all the parts and accessories with the packing list after unpacking the cartons.

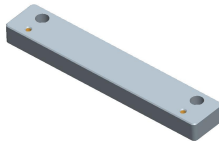
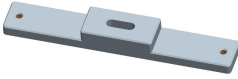
Major parts:

No.	Name	Item	Qty (Pcs)
1	Main bracket		1
2	Front fixing block		1
3	Rear fixing block		1

Accessories:

No.	Name	Item	Qty (pcs)	Spares (pcs)
1	cross recessed pan head tapping screw ST4.8×25		4	1
2	cross recessed countersunk head screw M3×8		4	1
3	cross recessed pan head screw M3×12		3	1

4	8 mm plastic expansion pipe		4	1
---	-----------------------------	---	---	---

- Secure the front and rear fixing blocks to the main bracket of wall hanging using two cross-recessed countersunk head screws M3X8 separately, as below figure shown:

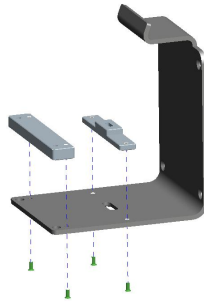

Installing the front and rear fixing blocks

- Put the main bracket of wall hanging on the wall with your hands, mark the four holes and take down the wall hanging; drill 4 holes of 30 mm depth in the marked position of the wall with a  $\phi$  8mm punch straight drill; Install an 8 mm plastic expansion pipe in each hole, align the wall hanging frame with the hole and attach it to the wall again, and make the wall hanging frame hook face up, and finally fix it with four cross recessed pan head tapping screws ST4.8x25, as shown in below figure:

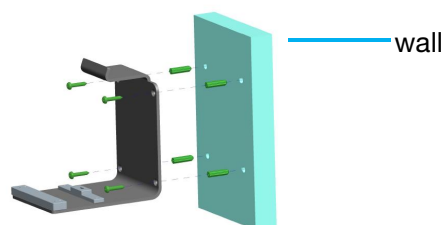

Installing the main bracket

#### Attaching the Monitor to the Wall Mounting Bracket

### **WARNING**

- Prior to mounting the monitor to the wall mounting bracket, check and ensure that wall mounting bracket is steady and intact.**
- The maximum load for the top splint board is 4.5 kg, and exceeding the rated load may result in fracture, and even toppling over.**

**NOTE:**

**When attaching the monitor to wall mounting bracket, please use the power cable (01.13.038197).**

1. Place the CS-04 or CS-05 stand on the wall mounting bracket. Hang the base handle on the hanger of wall mounting bracket.
2. Align the screw holes at the bottom of the base with the mounting holes on the wall mounting bracket, and secure the base using three M3x12 cross recessed pan head screws. As below figure shown:

The base handle shall be hanged on the wall mounting bracket

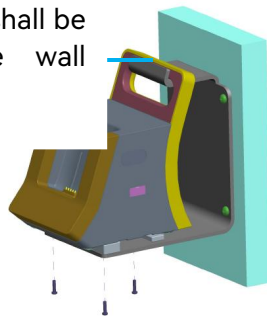

Align the screw holes at the bottom of the base with the mounting holes on the wall mounting bracket

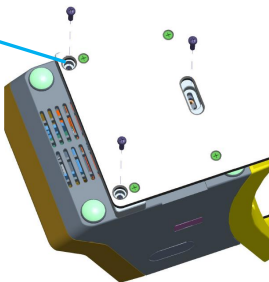

Installing the CS-04 or CS-05 stand

### 3.4 Checking the Monitor

Make sure there is no damage on the measurement accessories and cables. Then turn on the monitor, check whether the monitor can start normally. Make sure the indicator light flashes once in turn of three colors and a 'Di' tone sound is heard. If failed, please restart the monitor and check again. If still failed, please contact the service personnel.

---

**WARNING**

**If any sign of damage is detected, or the monitor displays some error messages, do not use it on any patient. Contact customer service center immediately.**

---

**NOTE:**

- 1 **Check all the functions of the monitor and make sure that the monitor is in good status.**
- 2 **If rechargeable batteries are provided, charge them after using the device every time, to ensure the electric power is enough.**
- 3 **After long-time continuous running, please restart the monitor to ensure the monitor's steady performance and long lifespan.**

### 3.5 Connecting Sensor to Patient

Connect all the necessary patient sensors between the monitor and the patient.

**NOTE:**

For information on correct connection, refer to *Measuring SpO<sub>2</sub>*.

### 3.6 Checking the Recorder

If your monitor is equipped with a recorder, open the recorder's door to check if paper is properly installed in the slot. If no paper exists, refer to Chapter *Recording* for details.

### 3.7 Setting Date and Time

To set the date and time:

1. Select **Menu > Date/Time**.
2. From left to right: year, month, day, hour, minute, second. Click the icon  on the upper right area to confirm the operation.
3. Set **Time Sync**: default is **Off**. **CMS/Gateway** is used for time synchronization with MFM-CMS/gateway.

**NOTE:**

- 1 **If the system is not used for a longer period of time, its system time may be inaccurate. In this case, readjust the system time after powering on.**
- 2 **If the system time cannot be saved and resumes the default value after restart, contact the service department of EDAN to replace the button cell in main board.**

## 3.8 Handing Over the Monitor

If you are handing over the monitor to the end-users directly after configuration, make sure that it is in normal working status and let user know the status.

The users must be adequately trained to use the monitor before monitoring a patient. To achieve this, they should have access to, and read, the following documentation delivered with the monitor:

- User Manual (this book) - for full operating instructions.
- Quick Guide - for quick reminders during use.

## 3.9 FCC Statement

This device complies with Part 15 of the FCC Rules. Operation is subject to the following two conditions:

- (1) This device may not cause harmful interference.
- (2) This device must accept any interference received, including interference that may cause undesired operation.

This equipment has been tested and found to comply with the limits for a Class B digital device, pursuant to part 15 of the FCC Rules. These limits are designed to provide reasonable protection against harmful interference in a residential installation.

### **NOTE:**

**“Harmful interference” is defined in 47 CFR §2.1 by the FCC as follows: Interference which endangers the functioning of a radio navigation service or of other safety services or seriously degrades, obstructs, or repeatedly interrupts a radio communication service operating in accordance with the [ITU] Radio Regulations.**

This equipment generates uses and can radiate radio frequency energy and, if not installed and used in accordance with the instructions, may cause harmful interference to radio communications. However, there is no guarantee that interference will not occur in a particular installation. If this equipment does cause harmful interference to radio or television reception, which can be determined by turning the equipment off and on, the user is encouraged to try to correct the interference by one or more of the following measures:

1. Reorient or relocate the receiving antenna.
2. Increase the separation between the equipment and receiver.
3. Connect the equipment into an outlet on a circuit different from that to which the receiver is connected.
4. Consult the dealer or an experienced radio/TV technician for help

**NOTE:**



**The manufacturer is not responsible for any radio or TV interference caused by unauthorized modifications to this equipment. Such modifications could void the user's authority to operate the equipment.**

### 3.10 FCC RF Radiation Exposure Statement

The SAR limit of USA (FCC) is 1.6 W/kg averaged over one gram of tissue. Device has also been tested against this SAR limit. This device was tested for typical body-worn operations with the back of the handset kept 10mm from the body, and 0mm for limb SAR. To maintain compliance with FCC RF exposure requirements, use accessories that maintain a 10mm separation distance between the user's body and the back of the handset. The use of belt clips, holsters and similar accessories should not contain metallic components in its assembly. The use of accessories that do not satisfy these requirements may not comply with FCC RF exposure requirements, and should be avoided.

## Chapter 4 Operator Login

Before measurement, user can login first to set the operator information.

1. Operator login: Click the shortcut key  , manually set **First Name**, **Last Name** and **ID**, or directly click the barcode scanning icon on the upper right area to get operator information to login.
2. Filing-time setting: Click the shortcut key  , click to enable **System Time** (it is enabled by default) and the saved data will be filed according to the system time of the device. Disable this function and click **Filing Time** to manually set the filing time.



Operator information and filing time can be viewed in **Review** window after user clicks **Save** in main interface.

## Chapter 5 Custom Parameters

The device allows user to input custom parameters which can be saved, filed and uploaded as measurement data.



### 1. Set the attribute of the custom parameters

Click **Menu > Custom Param.** to complete relevant settings, and the main interface will display the custom parameters correspondingly. The settings include:

- The master switch of custom parameters: Switch **Custom Param.** to on/off;
- General parameters: switch on/off or set unit of the general parameters (**TEMP, Glucose, Height, Weight, RR, Pain, Consciousness, Oxygen**);
- Add general parameters: click **Add General Parameters** to set **Name, Type** (**Numeric** and **Text** are optional), **Resolution, Upper Limit, Lower Limit, Unit**, and click  to confirm.
- Add In/Out Parameters: Click **Add I/O Parameter** to set **Name, Type, Unit, Upper Limit, Lower Limit, Resolution**, and click  to confirm.

All newly added parameters can be deleted.

### 2. Set detailed data information for the custom parameters

Click the icon  beside the Custom Parameter area in main interface to set the specific contents of corresponding custom parameters, and click  to confirm. The data will be filed and viewed in **Review** menu after user clicks **Save** in main interface.



## Chapter 6 Ward Round Mode

Ward Round mode is optimized for rapid multi-patient vitals capture and multiple patient data management (maximum 1000 patients).

### 6.1 Creating New Patient

To create new patient, you may:

1. Press Admit/Create New Patient hardkey on the front panel, or

2. Click **Select Patient** shortcut key  click , or

3. Scan patient barcode by clicking the barcode scanning icon  in main interface.

- If the scanned patient existed in the monitor already, this patient information will be inquired from the monitor directly.
- If the patient hasn't existed in the monitor, the **ADT Query** (in **Menu > Patient Info**) is turned on and network server is connected, the monitor will automatically inquire for patient information from the server.
- If the patient has not existed in the monitor or the server, the monitor will directly create new patient according to barcode information.

After input patient information, click Save button.

The patient information should be input, including:

- **MRN:** Enter the patient's medical record number.
- **Last Name:** Enter the patient's last name (family name).
- **First Name:** Enter the patient's first name.
- **Bed No.:** Enter the patient's bed No.
- **Gender:** **Male**, **Female** and **N/A**.
- **Type:** Choose the patient type, either **Adult**, **Pediat**, or **Neonat**. The patient category setting determines the algorithm which the monitor uses to process and calculate some measurements, the configurations that are applied for some measurements.

- **Date of Birth:** Enter the patient's date of birth.
- **Admission Date:** Enter the patient's date of admission.

---

### WARNING

---

**Changing the patient category may change the relevant configuration. Always check the configurations to make sure that they are appropriate for your patient.**

---

## 6.2 Editing Patient Information

To edit the admitted patient information, click the patient information area in main interface to enter Patient Info window, and make the required changes on the popup interface. Click **Save** button to confirm the operation.

If the monitor is powered off and restarted, the patient information will be restored by default, that is, the patient type is adult and the other information is blank.

## 6.3 Importing Patient

In **Menu > Patient Info > Import Patient** window:

If **ADT Query** is on and network server is connected, user can set the query conditions (**Admission Date, Department**), and click query icon  to show the patients.

Choose the patients as needed and click **Import** icon . After successful import, the imported patients will be displayed in the window of **Select Patient**, and marked

with icon .





### **NOTE:**

**In importing process, the monitor will import the patient information that meets the requirements, and prompt the wrong patient information. The wrong patient information needs to be revised and imported again.**

During importing, if the total patients in the monitor exceed upper limit (1000 patients), there will be a prompt. User can delete part of patients and import again.

## 6.4 Refreshing Patient List

Click **Select Patient** shortcut key  to enter the window:

If **ADT Query** is on and network server is connected, click  to set query conditions (**Admission Date, Department**), click  to confirm, and then click  to refresh patient list. All eligible patients will be refreshed to the window of **Select Patient**, and marked with icon .

### NOTE:

- 1 When importing patients, the patients those exist in the monitor but not searched in the networked will be reserved, while refreshing patients will be delete them.
- 2 If MRN or the bed No. has conflict, the monitor will replace all conflicting patient information. For MRN conflict, the monitor will keep the measurement status of the original patient unchanged, and for bed No. conflict, it will recover to the initial unmeasured status.

## 6.5 Selecting Patient for Measurement

Select the patient for measurement and the patient information will be displayed in the main interface. Click shortcut key  to enter the window of Select Patient:

- All patients are displayed in list. The mini circle on right of patient shows measurement status by colour. Green means patient has been measured and measurement data has been saved in Review; Yellow means patient is in measuring; Grey means patient hasn't been measured or there is no valid data.
- Select patient for current measurement: click one patient to view detailed information, and click **Measure** to start current patient's measurement.
- If new ward round is needed, press **New Round** to refresh all patients' measurement status. All patients will return to 'not measured' status.
- Click **Delete** to delete the selected patients.





If monitor is restarted, it will return to no patient status in main interface and keep the

previous measurement status in **Select Patient** interface.

## 6.6 Saving and Reviewing Data

Click **Save** in main interface to save one group of measurement data. The saved time is the ward round record time.

Click **Menu** > **Data Summary** to enter into **Review** interface. The user can perform below operations:

1. Multi-selection: click  on the upper right area to select data and **Upload**  to the network server, or **Export**  to removable storage device, or **Print**  data, or **Delete**  the selected data.

Before uploading, the device should be connected with network server. Please refer to chapter *HL7 Communication* for details. Data uploaded successfully will be marked with icon .

2. Single selection: click one group of data to view detailed patient information, measurement data, operator information, filing information, etc.
3. Filter operation: user can **Filter** the data by **All**, **Uploaded** or **Not Uploaded**. And the data will be displayed according to the filtering result.

If monitor is powered off, the parameters data in main interface will be cleared and ward round record will be stored.

## 6.7 Confirming Information

After the measurement is completed, in **Confirming Information** interface, the user can confirm the information including patient information, measured parameter data, manual input data, operator information, filing time, etc..



To edit, modify and overwrite the data of measurement parameters, the user can select **Settings** > **User Maintain** > **General** > **Enable Manual Override** > **On**. Before saving the patient's measurement data, the user can modify the patient's parameter measurement data, manual input data and filing time.

## Chapter 7 Spot-checking Mode

Spot-checking mode is used for spot-checking measurement and multiple patient data management.

### 7.1 Creating New Patient

To create new patient, you may:

1. Press Admit/Create New Patient hardkey on the front panel, or
2. Click **New Patient** shortcut key , or
3. Scan patient barcode by clicking the barcode scanning icon  in main interface.
  - If **ADT Query** (in **Menu > Patient Info**) is turned on and network server is connected, the monitor will automatically inquire for patient information from the server based on the identified MRN.
  - Otherwise, the monitor will create new patient according to barcode information.

After input patient information, click **Save** button to confirm the operation.

The patient information should be input, including:

- **MRN:** Enter the patient's medical record number.
- **Last Name:** Enter the patient's last name (family name).
- **First Name:** Enter the patient's first name.
- **Bed No.:** Enter the patient's bed No.
- **Gender:** **Male**, **Female** and **N/A**.
- **Type:** Choose the patient type, either **Adult**, **Pediat**, or **Neonat**. The patient category setting determines the algorithm which the monitor uses to process and calculate some measurements, the configurations that are applied for some measurements.
- **Date of Birth:** Enter the patient's date of birth.
- **Admission Date:** Enter the patient's date of admission.

## **WARNING**

**Changing the patient category may change the relevant configuration. Always check the configurations to make sure that they are appropriate for your patient.**

## 7.2 Editing Patient Information

To edit the admitted patient information, click the patient information area in main interface to enter Patient Info window, and make the required changes on the popup interface. Click **Save** button to confirm the operation.





If the monitor is powered off and restarted, the patient information will be restored by default, that is, the patient type is adult and the other information is blank.

## 7.3 Saving and Reviewing Data

Click **Save** in main interface directly to save one group of measurement data. The saved time is the spot-checking time.



Click  in main interface to perform following operations.

- Multi-selection: click icon  on the upper right area to select data and **Upload**  to the network server, or **Export**  to removable storage device, or **Print**  data, or **Delete**  the selected data.

Before uploading, the device should be connected with network server. Please refer to chapter *HL7 Communication* for details. Data uploaded successfully will be marked with icon .

- Single selection: click one group of data to view detailed patient information, measurement data, operator information, filing information, etc.
- Filter operation: user can **Filter** the data by **All**, **Uploaded** or **Not Uploaded**. And the data will be displayed according to the filtering result.

If monitor is powered off, the parameters data in main interface will be cleared and spot-checking data will be stored.

## 7.4 Confirming Information

After the measurement is completed, in **Confirming Information** interface, the user can confirm the information including patient information, measured parameter data, manual input data, operator information, filing time, etc..

To edit, modify and overwrite the data of measurement parameters, the user can select **Settings > User Maintain > General > Enable Manual Override > On**. Before saving the patient's measurement data, the user can modify the patient's parameter measurement data, manual input data and filing time.

## Chapter 8 Networking

The device can be connected to the wireless network and can be connected to hospital systems (such as HIS) via the HL7 protocol. If the monitor is networked, a

network icon  is displayed on the screen.

### 8.1 Cybersecurity Measures

#### 8.1.1 Personal Information Safety

Protecting personal health information is a major component of security strategy. To protect the personal information and ensure the proper device performance, the user should take necessary precautions in accordance with local laws and regulations and institution's policies. EDAN recommends health care organizations or medical institutions to implement a comprehensive and multifaceted strategy to protect the information and systems from internal and external security threats.

To ensure the patients' safety and protect their personal health information, the user should implement practices or measures that include:

1. Physical safeguards - physical safety measures to ensure that unauthorized personnel do not have access to the monitor.
2. Operational safeguards - safety measures during operation.
3. Administrative safeguards - safety measures in management.
4. Technical safeguards - safety measures in technical field.

---

#### **CAUTION**

- 1 The access/operation of the monitor is restricted to authorized personnel only. Assign only staff with a specific role the right to use the monitor.**
  - 2 Ensure that all device components maintaining personal information are physically secure.**
  - 3 Ensure that the monitor is connected only to the device authorized/approved by EDAN. Users should operate all EDAN deployed and supported monitors within EDAN authorized specifications, including EDAN approved software, software configuration, security configuration, etc.**
-



---

---

**CAUTION**

- 4 **Protect all the passwords to prevent unauthorized changes. Only the manufacturer's service personnel are allowed to modify the Factory Maintain settings.**
  - 5 **Anti-virus measures such as USB device virus scanning should be carried out prior to using USB flash drive.**
  - 6 **DoS and DDoS protection of the router or switch must be turned on for defending against attacks.**
  - 7 **When the monitor is returned for maintenance, disposed of, or removed from the medical institution for other reasons, it is necessary to ensure that all patient data are removed from the monitor (Refer to Section *Formatting the Internal Storage Device*).**
  - 8 **To avoid malicious tampering and theft of data transmitted by the network, it is recommended to switch on the encryption function. After the encryption function is turned on, the monitor will authenticate the accessed information system and encrypt the transmitted data to ensure the security.**
  - 9 **Please protect the privacy for the information and the data displayed on the screen, and for the information and the data stored in the monitor.**
  - 10 **When building the networking environment: 1) If a wireless router is used, please turn on the MAC address filtering function of the wireless router and add the MAC address of the monitor to the rule list. The wireless router only allows devices in the rule list to access the wireless network.**
- 
- 





## 8.2 Wi-Fi

Wi-Fi modules are optional to be configured in the monitors. To configure the settings on the monitor, follow the steps below before connecting the monitor to a wireless network:

1. Select **Menu > User Maintain > Server > Network Type > Wireless to Wi-Fi**, and set **Server IP**, **Server Port** and view the **Local Server** information.
2. Click **Menu** and switch on **Wi-Fi**.

3. The available networks will be listed in this interface. Networks signed with icon  indicate that password is required. Such networks are recommended.
4. Choose a network and enter the password if required.

If the selected network is successfully connected, clicking it directly can view the network information, such as **RSSI**, **IP** (DHCP or Static), **Gateway** and **Subnet Mask**. Also, a symbol indicating the networking state will be displayed in the icon area of the main interface. The meanings of the networking state symbols are explained below:

-  Wi-Fi signal intensity: Level 4
-  Wi-Fi signal intensity: Level 3
-  Wi-Fi signal intensity: Level 2
-  Wi-Fi signal intensity: Level 1

#### NOTE:

- 1 **Be aware that some network-based functions may be limited for monitors on wireless networks in comparison with those on wired networks.**
- 2 **The obstacle may interfere with data transmission and even cause data loss.**
- 3 **Use the wireless device recommended by EDAN, otherwise some exceptional situations such as frequent network disconnection may occur on the monitor.**
- 4 **When signal intensity is level 2 or less, signal may be unstable and quality of the signal transmission may be degraded.**
- 5 **When the monitor is connected to the wireless network, the user should set the router to a secure encryption/authentication and use the non-dictionary password.**
  - **Recommended options: WPA/WPA2 (supports AES/TKIP)**

---

---

#### **WARNING**

**If Wi-Fi is unavailable, please restart the monitor (refer to Section *Host*) to restore Wi-Fi function under the precondition of ensuring patient's safety.**

---

---

## 8.3 E-Link Function

A monitor with E-Link module can transmit data through E-Link and also displays E-Link connection status in the icons area.

To enable E-Link function:

1. Select **Menu > E-Link** to enable the function.
2. User can view the name of device.
3. Select data transmission direction: **Passive Connection** or **Active Connection**.
  - **Passive Connection** means sending the review data to medical institutions through HL7 protocol.  
Before connection, please enter **User Maintain** to set **E-Link Key**, and click **Server > Network Type > Wireless** to select **E-Link**. The E-Link key supports 6 digits at most, and the default is 123456.
  - **Active Connection** means receiving the measurement data from external TEMP module, such as HeTaiDa TEMP module.

Before connection, in **Menu > E-Link > Paired Devices**, up to 10 paired devices can be viewed. For the paired devices, user can modify **Alias** or view **MAC** address, etc. In the **Available Devices**, the available devices can be viewed, and user can select the desired device to connect.

### NOTE:

- 1 **The supported E-Link data transmission format is HL7, which is applicable in 3 system environments: iOS, Android and Windows.**
- 2 **When the monitor is powered off or enters standby mode, E-Link is automatically disconnected and needs to be reconnected next time.**

## 8.4 HL7 Communication

The monitor supports HL7 protocol to upload data.

To enable HL7 communication, Select **User Maintain > Network Setup > Server Type > HL7**.

To set HL7 IP address of the client-side, select **HL7 IP**.

For more information about HL7 communication, refer to *HL7 Communication Protocol Service Manual*.

## 8.5 ADT Query and Real-time Upload

When network server is connected, user can perform following operations:

- Upload data via network

In **Review** window, user can upload the selected data. Please refer to chapter *Save and Review* for uploading operations.

In **User Maintain**, if the **Real-time Upload** is turned on (default is on), the saved data can be uploaded to network in real time.

- Inquire for single patient information via network (applicable to Wi-Fi communication only).

Select **Menu > User Maintain > ADT Query** (default is on). The patient information can be directly obtained from network by manually inputting MRN and click search icon , or by scanning patient barcode.

- In ward round mode, user can import patients or refresh patients in batches based on **ADT Query** (applicable to Wi-Fi communication only).

Please refer to chapter *Ward Round Mode* for details.

### NOTE:

**If a conflict occurs when the monitor is connected to network, please modify the last number of monitor's Local IP/Net No. (in ward round mode or spot-checking mode).**

## Chapter 9 Prompts

The monitor can give the character indication of monitoring or system functions. And this character is called prompts.

Prompt sound	Indicator light	Prompts area
Mode is “DO”, which is triggered once every 8~10 seconds.	The indicator lights in blue when battery low and communication fail prompt.	The message displays in prompts area, with yellow background and black text.

---

### **WARNING**

- 1 Remember that the most reliable method of patient monitoring combines close personal surveillance with correct operation of monitoring equipment.**
  - 2 Ensure the volume is properly set up. When the sound pressure of audible prompt is below or equivalent to the ambient noise, it may be difficult for the operator to distinguish.**
-

## Chapter 10 Prompt Information

### 10.1 Technical Prompt

Message	Cause	Action Taken
SpO <sub>2</sub>		
<b>SpO<sub>2</sub> Sensor Off</b>	SpO <sub>2</sub> sensor may be disconnected from the patient measuring site.	Make sure the sensor is well connected to the patient's finger or other parts. Make sure the monitor and cables are well connected.
<b>SpO<sub>2</sub> Sensor Err</b>	Malfunction in the SpO <sub>2</sub> sensor or in the extension cable.	Replace the SpO <sub>2</sub> sensor or the extension cable.
<b>SpO<sub>2</sub> No Sensor</b>	No SpO <sub>2</sub> sensor was connected to the monitor.	Make sure the monitor and sensor are well connected, reconnect the sensor.
<b>SpO<sub>2</sub> Low Perfusion</b>	The pulse signal is too weak or the perfusion of the measurement site is too low.	Reconnect the SpO <sub>2</sub> sensor and change the measurement site. If problem exists, please notify biomedical engineer or manufacturer's service staff.
<b>SpO<sub>2</sub> Noisy Signal</b>	There is interference with SpO <sub>2</sub> measurement signals due to patient movement, ambient light, electrical interference or else.	Check the condition of patient and avoid patient movement; make sure the cable is well connected.
<b>SpO<sub>2</sub> Light Interference</b>	Ambient light around the sensor is too strong.	Reduce interference of the ambient light and avoid sensor's exposure to strong light.

Message	Cause	Action Taken
NIBP		
<b>NIBP System Failure</b>	NIBP is not calibrated.	Contact your service personnel.
<b>NIBP Leak</b>	NIBP pump, valve, cuff or tube has a leakage.	Check the connections and the wrapped cuff to see whether they are all prepared well. If failure persists, please notify biomedical engineer or manufacturer's service staff.
<b>NIBP Over Pressure</b>	Pressure has exceeded the specified upper safety limit.	Measure again, if failure persists, stop measuring function of NIBP module and notify biomedical engineer or manufacturer's service staff.
<b>NIBP Init Pressure High</b>	The initial pressure is too high during measuring	
<b>NIBP Aux Excessive Pressure</b>	Pressure has exceeded the second safety limit as specified.	Notify biomedical engineer or manufacturer's service staff.
<b>NIBP Time Out</b>	Measuring time has exceeded the specified time.	Measure again or use other measuring method.
<b>NIBP Self Test Error</b>	Sensor or other hardware errors.	Measure again, if failure persists, stop using measuring function of NIBP module and notify biomedical engineer or manufacturer's service staff.

Message	Cause	Action Taken
<b>NIBP Cuff Type Error</b>	The cuff type used isn't consistent with the patient type.	Confirm the patient type and change the cuff.
<b>NIBP SystemPress.Abnormal</b>	Atmospheric pressure or system pressure is abnormal. The valve is occluded so that deflation is failed.	Check whether the airway is occluded or pressure sensor works properly. If the problem still exists, contact your service personnel.
<b>NIBP Weak Signal</b>	Cuff is too loose or patient pulse is too weak.	Use other methods to measure blood pressure.
<b>NIBP Range Exceeded</b>	Maybe the patient blood pressure value is beyond the measurement range.	Use other methods to measure blood pressure.
<b>NIBP Loose Cuff</b>	Cuff is not properly wrapped or no cuff is connected.	Properly wrap the cuff.
<b>NIBP Interference</b>	Signal noise is too large or pulse rate is not regular due to the patient movement.	Make sure that the patient under monitoring is motionless.
<b>NIBP Leak Test Error</b>	During leak testing, deflation is failed.	Check the connections and the wrapped cuff to see whether they are all prepared well. If failure persists, please notify biomedical engineer or manufacturer's service staff.



Message	Cause	Action Taken
F3000 TEMP		
<b>TEMP Error P6</b>	Unable to pre-heat probe tip.	Stop using measuring function of TEMP module; notify biomedical engineer or Manufacturer's service staff.  <b>NOTE:</b> Measure readings displayed on the screen are unreliable when the monitor indicates Temp Error P06.
<b>Temp COMM Fail</b>	TEMP module failure or communication failure.	Stop using measuring function of TEMP module; notify biomedical engineer or Manufacturer's service staff.
<b>No TEMP Sensor</b>	Probe configuration (or no probe connected) error.	Well connect the probe and the monitor, and measure again.
<b>TEMP Error E1</b>	System error during synchronization.	Stop using measuring function of TEMP module; notify biomedical engineer or Manufacturer's service staff.
<b>TEMP Error E2</b>	System error during patient thermistor calibration.	
<b>TEMP Error E3</b>	System error during heater thermistor calibration.	
<b>TEMP Error E4</b>	System timing error.	

Message	Cause	Action Taken
<b>Probe Heater Error</b>	Heater error.	
<b>TEMP Error P2</b>	Monitor Mode patient thermistor unstable or out of range.	
<b>TEMP Error P3</b>	Monitor Mode heater thermistor unstable or out of range.	
<b>TEMP Error P4</b>	Predict Mode patient thermistor unstable or out of range.	
<b>TEMP Error P5</b>	Predict Mode heater thermistor unstable or out of range.	
<b>Measure Site Error</b>	The probe in use is not consistent with the measure position set on the monitor.	Correctly set the measure position on the monitor.
F3000 TEMP		
<b>TEMP Exceed Limit</b>	F3000 TEMP: The TEMP value is out of the range of +30 °C ~ +43 °C.	F3000 TEMP: Put the probe into the probe well; take it out and measure again.
IR20b TEMP		
<b>TEMP Exceed Limit</b>	IR20b TEMP measuring value is beyond measuring range (32 °C ~43°C).	Stop using measuring function of TEMP module; notify biomedical engineer or Manufacturer's service staff.

Message	Cause	Action Taken
Others		
<b>Battery Low</b>	The battery power of the monitor or the Stand is Low.	Please change the battery or charging.
<b>Battery1 Error</b>	Malfunction in Battery of the monitor	Replace the battery and restart the monitor. If the problem persists, notify the manufacturer's service staff.
<b>Battery 1 Overheated</b>	The temperature in battery of the monitor is too high.	Turn off the monitor in time and restart it after cooling.
<b>Battery1 Charge Voltage Too High</b>	The charging voltage in battery of the monitor is too high	Please replace the battery.
<b>Device Overheated</b>	The temperature of the monitor is too high.	Turn off the monitor in time and restart it after cooling.
<b>Recorder Out Of Paper</b>	Recorder Out Of Paper	Please install the paper.
<b>Recorder Setup Needed</b>	The user presses the <b>Record</b> button when Recorder is not configured.	Notify the manufacturer's service staff to install and set the recorder.

## 10.2 Operation Prompt

Message	Cause
<b>SpO<sub>2</sub> Searching Pulse</b>	SpO <sub>2</sub> module is analyzing the patient signal and searching for the pulse to compute the saturation, when sensor is connected with patient.
<b>Please Start</b>	NIBP module is in idle status.
<b>Measuring</b>	During NIBP measurement.

Message	Cause
<b>Measurem. Canceled</b>	During NIBP measurement, user presses the hardkey of Start/stop NIBP measurement.
<b>Done</b>	NIBP measurement is completed.
<b>Source: SpO<sub>2</sub> or NIBP</b>	PR source is displayed in parameters area.
<b>No Source</b>	Both SpO <sub>2</sub> and NIBP are off. PR has no source.
<b>Check whether the airway is connected to the atmosphere</b>	<ol style="list-style-type: none"> <li>1. In NIBP cleaning mode, if pressure keeps over 15 mmHg for more than or equal to 30 s±2 s;</li> <li>2. In NIBP cleaning mode, if pressure is more than or equal to 140 mmHg±3 mmHg;</li> </ol>
<b>Measure time out</b> (F3000 TEMP)	No measuring result after the module entering Predict state for 30 s.
<b>Probe TEMP Too High</b> (F3000 TEMP)	The initial temperature of the probe is at >+33 °C and ≤ +40 °C.
<b>TEMP Is Warming Up</b> (F3000 TEMP)	The monitor displays this message after taking the sensor out of the bracket and warm-up is in process.
<b>Predict Over</b> (F3000 TEMP)	After the Predict measuring is over, the data and message display on the interface.
<b>Quick Predict Over</b> (F3000 TEMP)	Quick prediction measurement is completed.

## Chapter 11 User Interface

Changing some settings may have the risk, so only the authorized person can change them. After changing the settings, please notify the operator.

### 11.1 Selecting Display Parameters

The user can select the display parameters based on requirements.

Click **Menu > Module Switch** to enable or disable the parameter module. Exit the menu and the screen will adjust the parameters automatically.

### 11.2 Default Configuration

Select **Menu > Module Switch > Restore Factory Defaults** to restore default settings for each parameter module.

Select **Menu > User Maintain > Default** to restore default settings for all parameters and the system settings at the same time.

## Chapter 12 Monitoring SpO<sub>2</sub>

### 12.1 Overview

SpO<sub>2</sub> is used to measure arterial blood oxygen saturation, which is the percentage of oxyhemoglobin in the arterial blood. SpO<sub>2</sub> parameter can also provide pulse rate (PR) and a plethysmogram wave (Pleth).

### 12.2 SpO<sub>2</sub> Safety Information

---

**WARNING**

---

- 1 Do not use the SpO<sub>2</sub> sensors if the packaging or the sensor is damaged and return them to the vendor.**
  - 2 If the SpO<sub>2</sub> sensor cannot work properly, please reconnect the sensor or change a new one.**
  - 3 Correct and proper sensor application: if the sensor is too loose, it might compromise the optical alignment, and even cause the sensor to fall off. If the sensor is too tight, (such as the application site is too large or becomes too large due to edema), excessive pressure and local tissue ischemia, hypoxia and lack of nutrition may occur on the application site. Prolonged and continuous monitoring may increase the risk of Skin irritations or lacerations. To avoid these damages, users should periodically check surrounding skin of application site according to the patient's condition and pressure sensor, inspect the if there is sign of stress-related damage in surrounding tissue, and regularly change the application site. For the patients whose fluid is easy to transfer and/or the patients with systemic or localized edema, users should inspect the skin and change application site more frequently.**
  - 4 Use only EDAN permitted sensors and extension cables with the monitor. Other sensors or extension cables may cause improper monitor performance and/or minor personal injury.**
  - 5 When serious arrhythmia is present, the SpO<sub>2</sub> pulse rate may differ from ECG heart rate but this does not indicate an inaccurate PR (SpO<sub>2</sub>) value.**
  - 6 Misapplied sensor or sensor that becomes partially dislodged may cause either over or under reading of actual arterial oxygen saturation.**
-

**NOTE:**

- 1 When a trend toward patient deoxygenation is indicated, analyze the blood samples with a laboratory co-oximeter to completely understand the patient's condition.**
- 2 SpO<sub>2</sub> waveform is not directly proportional to the pulse volume.**
- 3 The device is calibrated to display functional oxygen saturation.**
- 4 Functional tester or simulator cannot be used to assess the SpO<sub>2</sub> accuracy. However, it can be used to demonstrate that a particular monitor reproduces a calibration curve that has been independently demonstrated to meet a particular accuracy.**
- 5 If the surrounding temperature increases, the operator should pay attention to the site of poor perfusion, and increase the frequency of checking the skin and changing the measurement site to prevent burns. If the initial skin temperature is less than 35 °C, the temperature of all the listed sensors on the skin will not exceed 41 °C during working.**
- 6 The cumulative use time for SpO<sub>2</sub> sensor in a single patient should be less than 30 days.**

## 12.3 Measuring SpO<sub>2</sub>

1. Select the correct patient category setting (adult/pediatric and neonatal), as this is used to optimize the calculation of the SpO<sub>2</sub> and pulse numerics.
2. During measurement, ensure that the application site:
  - has a pulsatile flow, ideally with a good circulation perfusion.
  - has not changed in its thickness, causing an improper fit of the sensor.

### Measurement Procedure

1. Switch on the monitor.
2. Attach the sensor to the appropriate site of the patient.

#### Before Applying the Sensor

Be sure to understand all warnings listed in the previous section before applying any sensor to a patient. Also, check the sensor as follows:

- ◆ Check the sensor outside and inside. To inspect the inside, gently open the sensor cavity and check splits on or next to the transparent silicone that covers the optical elements.
- ◆ Any sensor showing signs of damage or alteration must not be used for further patient monitoring; instead, dispose of it using proper disposal procedures.

#### Applying Finger/Soft-tip Sensors:

- ◆ Nip the clamp, and choose a site that is well perfused and restricts a conscious patient's movements least. The right finger of the non-dominant hand is preferred. Alternatively, the other digits on the non-dominant hand may be used.
- ◆ The grate toe or long toe (next to the grate toe) may be used on restrained patients or patients whose hands are unavailable.
- ◆ Place the finger into the sensor according to the direction of the symbol on the sensor. The fleshiest part of digit should be covering the detector window.
- ◆ Orient the sensor so that the cable will be running towards the top of the patient's hand.
- ◆ Connect the sensor with the monitor (or with the extension cable if needed).

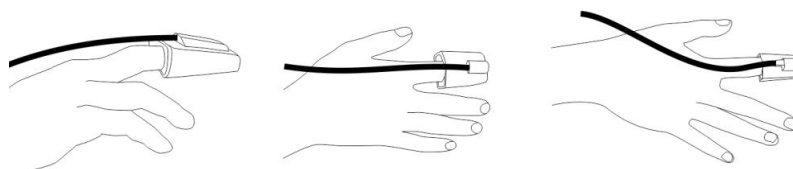

#### Applying Neonatal Finger (or Toe) Wrap Sensors:

- ◆ When you perform the measurement, position the sensor over the hand or foot with optical components opposite each other.
- ◆ Hold the sensor, and insert stretched strap into slot, hold it there while threading end through latch. If strap is too long, thread it through second latch.
- ◆ Connect the sensor with the monitor (or with the extension cable if needed).

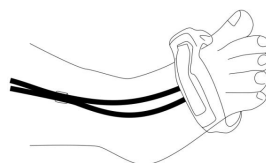

3. Plug the connector of the sensor extension cable into the SpO<sub>2</sub> socket.



---

---

**WARNING**

---

---

- 1 Inspect the application site every two to three hours to ensure skin quality and correct optical alignment. If the skin quality changes, move the sensor to another site. Change the application site at least every four hours.**
  - 2 For neonate, change the measuring site every 20 minutes.**
- 
- 

**NOTE:**

- 1 Injected dyes such as methylene blue or intravascular dyshemoglobins such as methemoglobin and carboxyhemoglobin may lead to inaccurate measurements.**
- 2 Inspect the sensor to ensure that the light emitter and receiver are aligned with each other and there is no gap between the sensor and the finger. All the light emitted by the light emitter must pass through the patient's tissue. The sensor cable should be placed on the back of the hand.**
- 3 Clean and remove any substances such as nail polish from the application site. Periodically check to ensure that the sensor remains properly positioned on the patient.**

## 12.4 Measurement Limitations

Certain patient conditions can affect the measurements or cause the loss of the pulse signal.

Inaccurate measurements can be caused but not limited by:

- incorrect sensor application
- high levels of ambient light sources, such as surgical lights (especially those with a xenon light source), bilirubin lamps, fluorescent lights, infrared heating lamps, and direct sunlight
- failure to cover the sensor with opaque material in high levels of ambient light conditions
- dysfunctional hemoglobins
- low peripheral perfusion

- excessive or violent patient movement
- venous pulsations
- intravascular dyes, such as indocyanine green or methylene blue
- externally applied coloring agents (nail polish, dye, pigmented cream)
- defibrillation
- placement of the sensor on an extremity with a blood pressure cuff, arterial catheter, or intravascular line
- electromagnetic interference

Loss of pulse signal can occur for the following reasons:

- the sensor is applied too tightly
- a blood pressure cuff is inflated on the same extremity as the one with the sensor attached
- there is arterial occlusion proximal to the sensor
- low peripheral perfusion

**NOTE:**

- 1 To prevent interference from ambient light, ensure that the sensor is properly applied, and cover the sensor site with opaque material.**
- 2 Adjacent SpO<sub>2</sub> sensors may interfere with each other (eg, multiple SpO<sub>2</sub> measurements in the same patient). Be sure to cover the sensor with opaque material to reduce cross-interference.**
- 3 Move the sensor to a less active site, and keep the patient still, if possible.**

## 12.5 Assessing the Validity of a SpO<sub>2</sub> Reading

You can check the quality of the pleth wave and the stability of the SpO<sub>2</sub> values to assess whether the sensor functions properly and whether the SpO<sub>2</sub> readings are valid. Always use these two indications simultaneously to assess the validity of a SpO<sub>2</sub> reading.

Generally, the quality of the SpO<sub>2</sub> pleth wave reflects the quality of the light signals obtained by the sensor. A wave of poor quality manifests a decline of the signal validity. On the other hand, the stability of the SpO<sub>2</sub> values also reflects the signal quality. Different from varying SpO<sub>2</sub> readings caused by physiological factors,

unstable SpO<sub>2</sub> readings are resulted from the sensor's receiving signals with interference. The problems mentioned above may be caused by patient movement, wrong sensor placement or sensor malfunction. To obtain valid SpO<sub>2</sub> readings, try to limit patient movement, check the placement of the sensor, measure another site or replace the sensor.

**NOTE:**

- 1 The SpO<sub>2</sub> accuracy has been validated in controlled human studies against arterial blood sample reference measured with a CO-oximeter. SpO<sub>2</sub> measurements are statistically distributed, only about two-thirds of the measurements can be expected to fall within the specified accuracy compared to CO-oximeter measurements. The volunteer population in the studies are composed of healthy men and women from age 18 to 50, with various skin pigmentations. Note that the study population was healthy adults and not in the actual intended use population.**
- 2 The pulse rate accuracy is obtained by comparison to the pulse rate generated with an arterial oxygen simulator (also an electronic pulse simulator).**
- 3 During monitoring, if the monitor's reading differs significantly from the patient's physiological condition, it indicates that the signal may be disturbed, resulting in an inaccurate reading. In this case, the artifact can disguise as a similar reading, causing the monitor to fail to send an prompt. In order to ensure reliable monitoring, it is necessary to regularly check whether the sensor is wearing properly and the signal quality is good.**

## 12.6 SpO<sub>2</sub> Prompt Delay

There is a delay between a physiological event at the measurement site and the corresponding prompt at the monitor. This delay has two components:

The time between the occurrence of the physiological event and when this event is represented by the displayed numerical values. This delay depends on the algorithmic processing time and the sensitivity setting. The lower the sensitivity configured, the longer the time needed until the numerical values reflect the physiological event.

## 12.7 Perfusion Index (PI)

PI is a numeric value indicating perfusion level. It reflects the perfusion level at the monitoring site.

As the measurement of SpO<sub>2</sub> is based on the pulsation caused by the blood flow through the vessel, PI is in relation to the strength of the pulse. Also, you can use PI as a signal quality indicator for the measurement of SpO<sub>2</sub>.

PI is indicated by a value ranging from 0 to 10. The bigger the value is, the better the perfusion and the signal quality will be. The perfusion level and the signal quality are at their maximum when the value reaches 10. When PI is below 2, it indicates the low perfusion and the poor signal quality at the monitoring site; you need to reposition the sensor or find a better site.

The PI value will be displayed in the SpO<sub>2</sub> parameter area.

## 12.8 Setting Pitch Tone

If tone modulation is on, the PR sound lowers when the SpO<sub>2</sub> level drops. In **Menu > Module Switch**, select **Pitch Tone** to toggle between On and Off. The lower SpO<sub>2</sub> value is, the lower the frequency of Pitch tone is.

## 12.9 Setting Sensitivity

The different sensitivity indicates different refresh frequency. **High** indicates the refresh frequency of SpO<sub>2</sub> value is the most frequent. To change the sensitivity, please follow the steps:

- 1 Select **Menu > Module Switch**;
- 2 Select **Sensitivity** on the interface and select the desired sensitivity from the popup list.

## 12.10 SpO<sub>2</sub> Relevant Data for Reference

1. The table below shows Arms values measured using with SH series sensors in a clinical study.

SaO <sub>2</sub> Range	Arms			
	With SH1	With SH3	With SH4	With SH5
90%-100%	1.01	1.07	1.29	1.10
80%-90%	2.01	2.30	2.17	2.13
70%-80%	2.01	2.65	2.29	2.57
70%-100%	1.68	1.99	1.89	1.90

2. The figures below show the Bland-Altman Plot of SaO<sub>2</sub> vs SpO<sub>2</sub> measured using SH series sensor. In the plots, the upper and lower dotted lines represent the upper and inferior limits of the 95% consistency, and the middle dotted line represents the average of the bias.

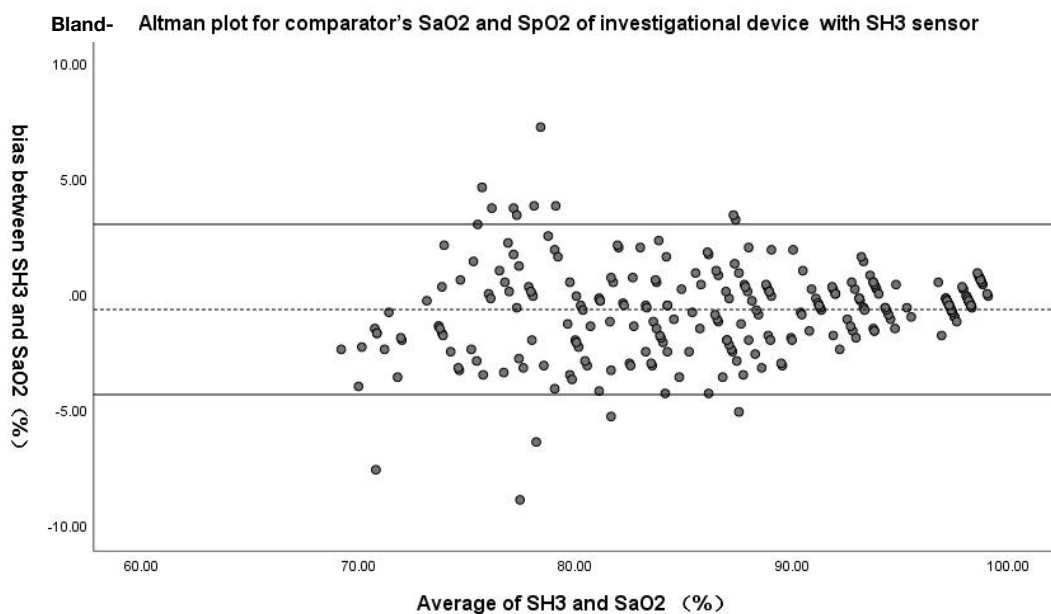
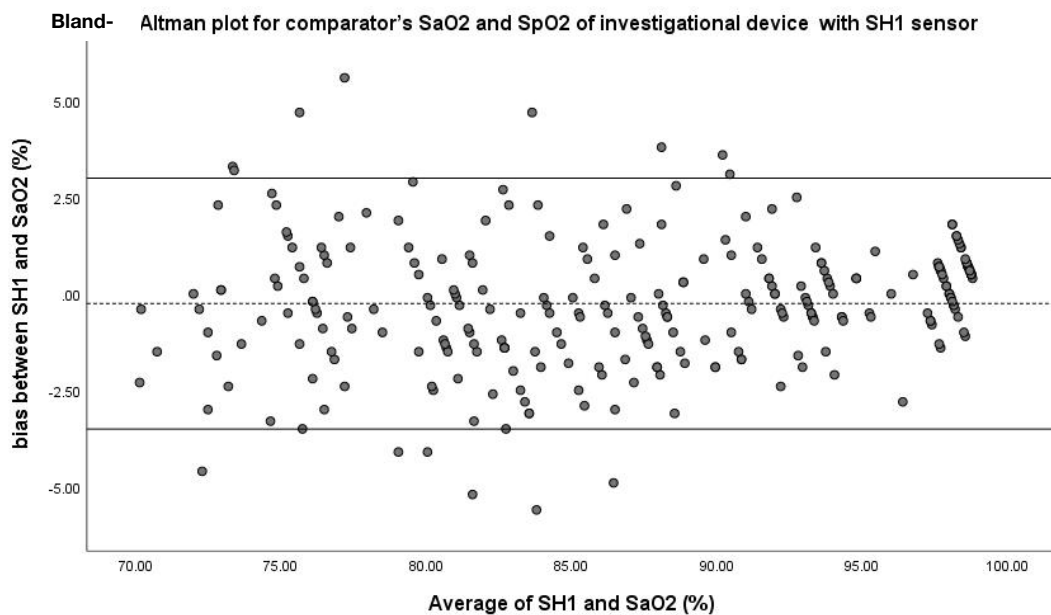

**Bland-** Altman plot for comparator's SaO<sub>2</sub> and SpO<sub>2</sub> of investigational device with SH4 sensor

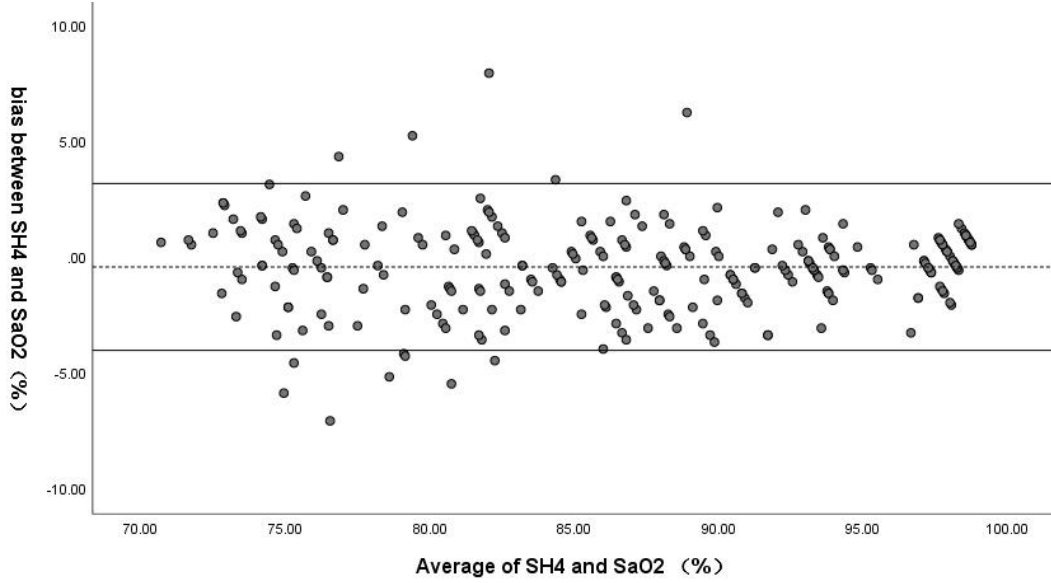

**Bland-** Altman plot for comparator's SaO<sub>2</sub> and SpO<sub>2</sub> of investigational device with SH5 sensor

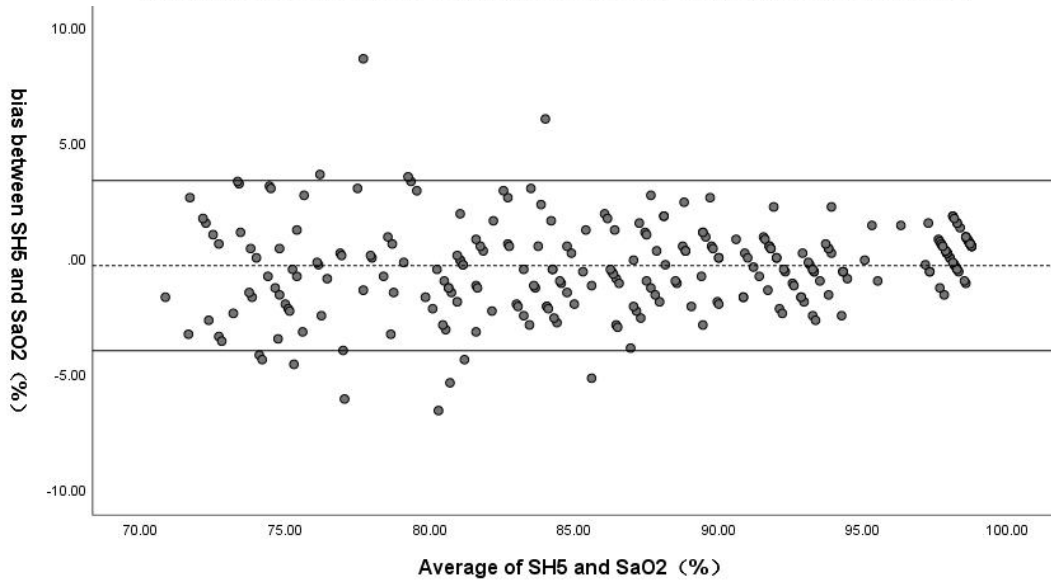

## Chapter 13 Monitoring PR

### 13.1 Overview

The pulse numeric counts the arterial pulsations that result from the mechanical activity of the heart in beats per minute (bpm). You can obtain a pulse from any measured SpO<sub>2</sub> signal or NIBP measurement.

### 13.2 PR Source

PR source can be from SpO<sub>2</sub> or NIBP, and is not selectable. SpO<sub>2</sub> is preferred source if PR from SpO<sub>2</sub> is valid. If PR is on, and SpO<sub>2</sub> & NIBP both are off, PR parameter area will display **No source**.

### 13.3 Setting PR Volume

Select **Menu > Module Switch**, then select the appropriate setting for the PR volume. Beat frequency has positive correlation with measurement value.

## Chapter 14 Monitoring NIBP

### 14.1 Overview

This monitor uses the oscillometric method for measuring NIBP. It can be used for adult, pediatric and neonatal patients. It is also intended for use with pregnant, including pre-eclamptic patients.

Oscillometric devices measure the amplitude of pressure changes in the occluding cuff as the cuff deflates from above systolic pressure. The amplitude suddenly increases as the pulse breaks through the occlusion in the artery. As the cuff pressure decreases further, the pulsations increase in amplitude, reach a maximum (which approximates to the mean pressure), and then diminish.

The blood pressure measurements determined with this device comply with the American National Standard for Electronic or Automated Sphygmomanometers (ISO 81060-2:2013) in relation to mean error and standard deviation. In clinical investigation method with a reference sphygmomanometer, the fifth Korotkoff sound was used to determine adult diastolic pressure, and the fourth Korotkoff sound was used to determine pediatric diastolic pressure.

The invasive blood pressure is used to determine the neonate pressure in clinical investigation, and the arterial reference sites include umbilical artery, arteria cruralis, axillary artery, brachial artery, dorsalis pedis, and radial artery.

When selecting the patient type on the patient admitting interface, it is recommended to choose **Adult** for patients greater than 21 years of age, **Pediat** for patients greater than 3 through 21 years of age and **Neonat** for patients from birth through 3 years of age.

### 14.2 NIBP Safety Information

---

---

#### **WARNING**

- 1 Do not measure NIBP on patients with sickle-cell disease or any condition where skin damage has occurred or is expected.**
  - 2 Do not apply the cuff to a limb that has an intravenous infusion or catheter in place. This could cause tissue damage around the catheter when infusion is slowed or blocked during cuff inflation.**
- 
-



---

---

**WARNING**

---

---

- 3 Do not measure NIBP on the arm of the same side with a mastectomy.**
  - 4 Use clinical judgement to decide whether to perform frequent blood pressure measurements on patients with severe blood clotting disorders because of the risk of hematoma in the limb fitted with the cuff.**
  - 5 Do not attach the cuff to a limb being used for IV infusions as the cuff inflation can block the infusion, potentially causing harm to patient.**
  - 6 Do not apply the cuff to a limb where intravascular access or therapy, or an arterio-venous (A-V) shunt is present, otherwise, it may result in injury to the patient.**
  - 7 Ensure that the correct patient type is selected before performing measurements. Do not apply the higher adult inflation, overpressure limits and measurement duration for neonatal patients. Not using the neonate mode on a neonatal patient can block the blood flow, potentially causing harm to the patient.**
  - 8 Make sure that the air conduit connecting the blood pressure cuff and the monitor is neither blocked nor tangled.**
  - 9 Measuring of blood pressure can temporarily cause malfunctioning of other medical monitoring devices on the same limb.**
  - 10 NIBP readings can be affected by the measurement site, the position of the patient, exercise, or the patient's physiologic conditions.**
  - 11 Continuous cuff pressure due to connection tubing kinking can block the blood flow, and may result in injury to the patient.**
  - 12 Verifying the calibration is only applicable for adults, and it cannot be operated in AVG measuring interval. Continuous measuring cannot be operated in AVG measuring interval either.**
- 
- 

**NOTE:**

- 1 It is suggested that the user should not start NIBP measuring when the low battery displays, or the monitor may be turned off automatically.**
- 2 If you spill liquid onto the equipment or accessories, particularly if there is a**

**chance that it can get inside the tubing or the measurement device, contact your service personnel.**

- 3 Continuous measuring in neonatal or pediatric mode may result in tissue damage or ischemia to the patient.**
- 4 NIBP measurement can be affected by extremes of temperature, humidity and altitude.**
- 5 NIBP measurement value should be explained by qualified professionals.**
- 6 The pulse rate based on the NIBP measurement may differ from the heart rate based on the ECG waveform. NIBP measures the number of peripheral pulse pulsations, and the heart rate is measured by the electrical signal of the heart. When the electrical signals of the heart occasionally fail to cause the peripheral blood vessels to pulse or the patient's peripheral perfusion is poor, the difference happens.**
- 7 The cumulative use time for NIBP cuff in a single patient should be less than 30 days.**

### 14.3 Measurement Limitations

Measurements are impossible with pulse rate extremes of less than 40 bpm or greater than 240 bpm, or if the patient is on a heart-lung machine.

The measurement may be inaccurate or impossible in the following situations:

- A regular arterial pressure pulse is hard to detect.
- Patients with cardiac arrhythmias.
- Patients with excessive and continuous movement such as shivering or convulsions.
- Patients with rapid blood pressure changes.
- Patients with severe shock or hypothermia that reduces blood flow to the peripheries.
- Patients with obesity, where a thick layer of fat surrounding a limb dampens the oscillations coming from the artery.
- Patients on an edematous extremity.

## 14.4 Measurement Methods

There are three methods of measuring NIBP:

- Manual - measurement on demand. Manual is the default setting in round and spot-checking mode.
- Continual- the measurement will run consecutively in five minutes with intervals of 5 seconds, then the monitor enters manual mode.
- Average - between 1 and 5 minute adjustable AVG interval, measurement will run as specified AVG times (3 or 5 times are optional), then gets average value. After finishing average measurement, the monitor enters manual mode.

To change Measure Mode, Interval, AVG Measurement Interval and AVG Measurement Times, please slide NIBP parameter area left to select and set as needed, and start the measurement.

---

---

### **WARNING**

**Prolonged non-invasive blood pressure measurements in Continual mode may be associated with purpura, ischemia and neuropathy in the limb wearing the cuff. When monitoring a patient, examine the extremities of the limb frequently for normal color, warmth and sensitivity. If any abnormality is observed, stop the blood pressure measurements.**

---

---

## 14.5 Measurement Procedures

To obtain accurate measurements, the following operating steps need to be observed:

1. Ensure the patient position in normal use, including
  - ◆ Comfortably seated or lie flat, legs uncrossed;
  - ◆ Feet flat on the floor
  - ◆ Back and arm supported
  - ◆ Relax as much as possible, neither talking nor applying external pressure against the cuff. Rest for five minutes in a quiet environment.
2. Connect the air hose and switch on the monitor.

Apply the blood pressure cuff to the patient's arm or leg and follow the instructions below.

-Ensure that the cuff is completely deflated.

-Apply the appropriate size cuff to the patient (About the cuff size selection, please refer to Section *NIBP accessories*), and make sure that the symbol "Φ" is over the artery. Ensure that the middle of the cuff is at the level of the right atrium of the heart and the cuff is not wrapped too tightly around the limb. Excessive tightness may cause discoloration and eventual ischemia of the extremity.

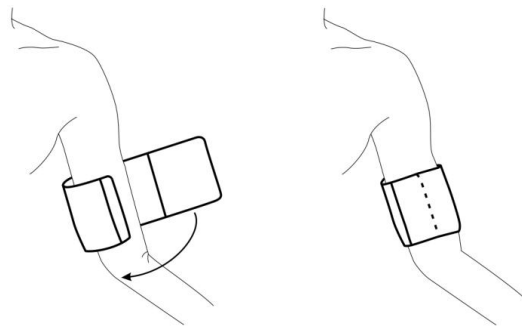

Cuff Usage

3. Check whether the patient type is appropriately selected. Clicking patient information area can change patient **Type**.
4. Access **Menu > Module Switch > Unit** (mmHg or kPa, 1 mmHg = 0.133 kPa).
5. Slide NIBP parameter area left to select and set as needed, and to start the measurement.
6. Wait until the first reading is taken.

**NOTE:**

- 1 **The width of the cuff is either approximately 40% of the limb circumference or 2/3 of the upper arm length. The inflatable part of the cuff should be long enough to encircle 80-100% of the limb. The wrong size of cuff can cause erroneous readings. If the cuff size is in question, use another cuff with suitable size to avoid errors.**
- 2 **If an NIBP measurement is suspect, repeat the measurement. If you are still uncertain about the reading, use another method to measure the blood pressure.**
- 3 **Please make sure the cuff is well connected. A leak of air may cause**



**measurement error.**

- 4 Please select the cuff with the suitable size. An unsuitable cuff may cause incorrect measurements.**
- 5 Avoid incursion of liquid into the cuff. If this happens, please desiccate the cuff completely.**
- 6 NIBP parameter area can display real-time cuff pressure value till displaying SYS value.**
- 7 Parameter area displays measured value for 30 mins. If there is no measurement to continue, the area will display invalid value after 30 mins.**

### 14.5.1 Operation Prompts

Slide NIBP parameter area left to select and set:

1. Manual Measuring

Click  or press the  button on the front panel to start measurement.



2. Continuous measurement



Click  to start measurement. The continuous measurement will last 5 minutes with a fix interval of 5 seconds.

3. **AVG** measurement

Click , set the interval and times, and click **Confirm** to start measurement.

4. Stopping measurement

During measurement, click  or press the  button on the front panel at any time to stop measurement.

For continuous and AVG measurement, NIBP parameter area will display the countdown time, and the measurement will continue after the countdown. To exit the whole measurement mode, click the corresponding measurement icon ,  again.

## 14.6 Resetting NIBP

When the pressure does not work properly and the system fails to give a message for the problem. Please click **Menu > User Maintain > Reset** to activate self-test procedure, and thus restore the system from abnormal performance.

## 14.7 Calibrating NIBP

NIBP is not user-calibrated. Cuff-pressure transducers must be verified and calibrated, if necessary, at least once every two years by a qualified service professional. See the Service Manual for details.

## 14.8 Leakage Test

Leakage test is used to detect the air tightness of the NIBP pump, valve, and trachea. If not, the system will display NIBP leakage. NIBP leak detection should be performed at least once every two years or when you think the measurement is inaccurate.

---

### **WARNING**

**This leakage test other than being specified in the ISO 81060-1 standard is to be used by the user to simply determine whether there are air leaks in the NIBP airway. If at the end of the test the system gives the prompt that the NIBP airway has air leaks, please contact the manufacturer for repair.**

---

### Procedure of Leakage Test

1. Connect the cuff securely with the socket for NIBP air hole.
2. Wrap the cuff around the cylinder of an appropriate size; don't wrap the cuff around limbs.
3. Make sure the patient type has been set to **Adult**.
4. Select **Menu > User Maintain > Leakage Test**. Then the prompt **Leak. Test Running** will appear indicating that the system has started the leakage test.

The system will automatically inflate the pneumatic system to about 180 mmHg. After 20 seconds to 40 seconds, if system leakage has detected, the system will automatically open the deflating valve to stop the leak test and indicates **NIBP Leak**.

If no system leakage is detected when the pneumatic system is inflated to 180 mmHg, the system will perform a deflation to an approximate value of 40 mmHg and subsequently perform the second phase leak test. After 20 seconds to 40 seconds, the system will automatically open the deflating valve and provide corresponding indication based on the test result.

5. If the information **NIBP Leak** appears, it indicates that the airway may have air leaks. In this case, the user should check for loose connection. After confirming secure connections, the user should re-perform the leakage test. If the failure prompt still appears, please contact the manufacturer for repair.

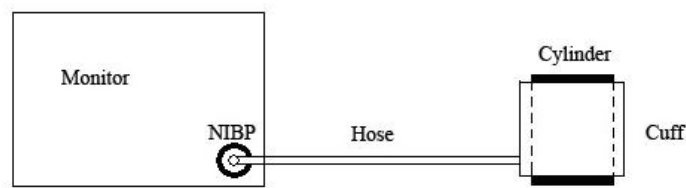

Diagram of NIBP Air Leakage Test

## 14.9 Setting Inflation Value

To change the inflation value:

1. Select **Menu > Module Switch > Inflation value**;
2. Choose **AUTO** or other inflation values from the pull-down list.
  - ◆ If other inflation values are chosen, the preset value by users will be adopted as the inflation value when measuring blood pressure.
  - ◆ If **AUTO** is chosen, the default value will be adopted as the inflation value when measuring blood pressure.

## 14.10 Manometer Mode

The device supports manometer function to check whether the relative pressure coefficient in the NIBP measurement is accurate.

Access **Menu > User Maintain > Manometer**. The device will display the pressure value in real time and prompt 'pressure testing'.

To exit, click the Back symbol < on top left area.

## 14.11 Cleaning Mode

The device supports cleaning mode for NIBP dust removal maintenance, which is applicable to adult and under the precondition that the cuff is removed from the device.

Access **Menu > User Maintain > Cleaning Mode**. The device will display the pressure value in real time, prompt 'cleaning', and display 3-minute countdown. During the cleaning, user can use dry cotton swab to clean NIBP port.

To exit, click the Back symbol < on top left area.



## Chapter 15 Monitoring TEMP

Before measurement, please select **Menu > Module Switch > Unit** (°C or °F).

### 15.1 Quick TEMP with F3000 Module

#### 15.1.1 Introduction

iM3s series with the F3000 module measure patient temperatures by oral, axillary or rectal means.

The monitor can only measure temperature of adult and pediatric (not neonatal) patients.

The electromagnetic compatibility of this device has been verified by test according to the EN60601-1-2 requirements.

---

---

#### **WARNING**

- 1 Do not use this device near flammable anesthetics. Not suitable for use in the presence of flammable anesthetic mixture with air, oxygen or nitrous oxide.**
  - 2 Do not use this thermometer without first installing a new probe cover.**
  - 3 Do not reuse the disposable probe covers.**
  - 4 Use probe covers supplied by the manufacturer with this thermometer only. Use of any other probe cover will result in erroneous temperature readings.**
  - 5 The thermometer and probe covers are Non-sterile. Do not use on abraded tissue.**
  - 6 To limit cross contamination, use Blue devices for Oral and Axillary temperature taking only.**
  - 7 Use RED devices only for RECTAL temperatures.**
  - 8 Thoroughly dry all electrical contacts on both probe and thermometer after washing, or device may fail to function properly.**
  - 9 For re-calibration, service or integrity checks, refer to a qualified Biomedical Technician or return to the manufacturer.**
- 
-

---

---

**WARNING**

---

---

- 10 Disposal of used probe covers must be performed in accordance with current medical practices or local regulations regarding disposal of infectious, biological medical waste.**
  - 11 Do not open the F3000 module. No user-serviceable parts inside. Opening of the module may affect calibration and voids warranty.**
  - 12 Cleaning frequency and practices must be consistent with institutional policy for cleaning of non-sterile devices.**
  - 13 The F3000 module is not intended for neonatal patients.**
  - 14 In monitoring mode of TEMP module, no physiological prompts are available.**
  - 15 Verification of the temperature module is necessary as frequently as dictated by your Hospital Procedures Policy. When you need to calibrate the temperature measurement, please contact the manufacturer.**
  - 16 Do not use the TEMP module if it has been immersed in liquid.**
- 
- 

**NOTE:**

- 1. Even though this device has been designed to minimize the effects of electromagnetic interference, it does generate radio frequency energy. If not used in accordance with the instructions, the device could cause interference in other equipment operating within its vicinity. If the device is causing interference, the following actions may be taken in an attempt to correct the interference:**
  - Re-orient or re-locate the receiving device.**
  - Increase the separation between the devices.**
  - Consult a customer service representative.**
- 2. Regular preventive maintenance should be carried out every two years. You are responsible for any requirements specific to your country.**
- 3. The reference body site temperature is the same as the temperature of the measuring site.**
- 4. The cumulative use time for the oral or rectal temperature probe in a single**

**patient should be less than 24 hours.**

### 15.1.2 Probe Covers —Applying & Removing

1. Open probe cover box by lifting tab at top corner and pulling to remove top panel.
2. Insert box of probe covers into top of isolation chamber.

**NOTE:**

**To aid infection control, never switch boxes between blue and red isolation chambers. Also, never switch probes between blue and red isolation chambers. Keep like colors together.**

3. Remove probe from the probe well. This automatically turns on the thermometer.
4. To help remind the user to apply or remove a probe cover, a probe icon with flashing probe cover will be displayed when the probe is withdrawn from the probe well and following a completed temperature measurement.
5. Insert the probe end into a cover in the box. Push the handle firmly until you feel the cover “snap” into place.
6. Take appropriate temperature measurement (oral, axillary or rectal).
7. Eject the used cover into bio-waste container by pressing top button.
8. Remove, discard and replace box when empty.

### 15.1.3 Changing Isolation Chambers and Probes

**NOTE:**

**1 For aiding in infection control, use only the Blue probe and Blue isolation chamber for Oral and Axillary temperature taking. The Red probe and Red isolation chamber must only be used for rectal temperature taking.**

**2 Do not attach a Red probe to a Blue isolation chamber or vice-versa.**

1. To remove or replace any isolation chamber/probe assembly, grasp the isolation chamber from each side
2. Squeeze inward releasing the snaps and slide the isolation chamber up to pull off.
3. To replace, align probe well finger with opening in the top of the unit.

4. Slide the isolation chamber down until the side snaps “click” into place.
5. The probe is connected to the thermometer automatically.
6. To change probes, remove the isolation chamber as described previously.
7. Grasp the sides of the L-shaped connector piece with one hand and then using other hand pull backward on the latch holding the end of the L-shaped connector.
8. Once free of the latch, slide the L-shaped connector out of isolation chamber.
9. To replace, properly align the top of the L-shaped connector to the slot on the back of the isolation chamber.
10. Then slide the connector up into the slot pressing firmly on the bottom of the connector until it “clicks” into place.

## 15.1.4 Measuring Mode

### **Predictive Mode**

When **MEASURE MODE** is set to **PREDICT**, the monitor operates in Predictive Mode to provide fast and accurate temperature measurements.

### **Quick Predictive Mode**

When **MEASURE MODE** is set to **QUICK PREDICT**, the monitor operates in Quick Predictive Mode which is an oral predictive measurement mode intended for situations where fast temperature measurements are desired.

Quick Predictive Mode allows clinicians to rapidly identify patients with “normal” body temperatures. If the patient temperature is outside of the “normal” range, the monitor will automatically switch into its standard predictive mode to provide a more accurate reading.

Quick Predictive Mode is not available when in Low Temp. Mode.

### **Monitoring Mode**

When **MEASURE MODE** is set to **MONITOR**, the monitor will perform continual temperature measurement for a maximum of 10 minutes. Only measure mode ‘**MONITOR**’ can be displayed in TEMP parameter area.

Besides, in the following instances, the monitor will automatically switch to Monitoring

Mode and perform temperature measurement for a maximum of 5 minutes until the temperature stabilizes:

1. When the monitor operates in Predictive Mode, no measurement site is detected or the temperature does not stabilize.
2. When the monitor operates in Predictive Mode or Quick Predictive Mode, the ambient temperature is greater than 35 °C (95 °F).

### **Low Temp. Mode**

Low Temp. Mode is provided for use in applications where body temperatures may be lower than “normal”, such as for patients recently out of surgery.

The accuracy and measurement time of Low Temp. Mode measurements are equivalent to standard prediction measurements at the respective body sites.

## 15.1.5 Measuring Procedure

### **Oral and Axillary Temperature Taking**

1. Make certain that the Blue isolation chamber /probe unit is attached.
2. Withdraw probe and apply a probe cover. The thermometer turns on automatically and a beep will be heard when the probe completes warm-up.
3. For Oral temperatures, insert the probe tip deep into the sublingual pocket next to the frenulum linguae, (vertical fold of tissue in middle of tongue), on one side or the other, toward the back of the mouth.

#### **NOTE:**

**Accurate body temperature readings can only be obtained in one of these two “heat pocket” locations as shown. Temperatures taken in other mouth locations will result in inaccurate body temperature readings.**

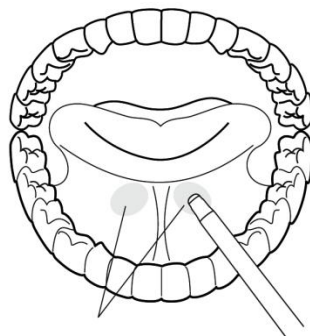

4. Patient's mouth must be CLOSED.
5. Securely hold the probe in place until the temperature is displayed.
6. For Axillary temperatures, have the patient raise the arm, then place the probe tip in the axilla. Press gently to assure good contact. For the most accurate temperature the probe tip should be placed directly against the patient's skin.
7. Have the patient then lower the arm and remain as still as possible. Hold the probe parallel to the arm as shown.

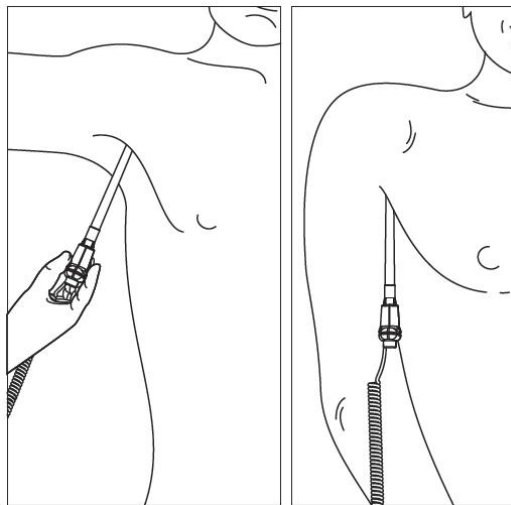

8. If three short beeps are heard, it means the unit switched to Monitoring Mode for this temperature only.
9. Two beeps are sounded when measurement is complete and the final temperature is displayed.
10. Eject the used cover into a bio-waste container by pushing top button.

### **Rectal Temperature Taking**

1. Make certain that the Red isolation chamber/probe unit is attached.
2. Withdraw the probe and apply a probe cover. Thermometer turns on automatically a beep will be heard when the probe completes warm-up.
3. Apply lubrication if desired.
4. Insert the probe into the patient's rectum. To ensure proper tissue contact, angle the probe slightly after insertion.\*
5. Depth of insertion is recommended at 1/2" to 3/4" (12 mm ~ 19 mm) for adults and 1/4" to 1/2" (6 mm ~ 13 mm) for children.

6. If three short beeps are heard, it means the unit switched to Monitoring Mode for this temperature only.
7. Two beeps are sounded when measurement is complete and the final temperature is displayed.
8. Eject the used cover into a bio-waste container by pushing top button.

**NOTE:**

- 1 **Probe movement during a measurement can affect the thermometer's ability to measure the site temperature and may lengthen the time required to obtain a reading.**
- 2 **If a beep is not heard 10 seconds after withdrawing the probe from the probe well and starting temperature measurement in Predictive Mode or Quick Predictive Mode, check the physical connection of the F3000 module.**

### 15.1.6 TEMP Setup for F3000 Module

In **TEMP SETUP** window, the following settings are available:

**MEASURE MODE:** Set the measuring mode to **PREDICT**, **QUICK PREDICT** or **MONITOR**.

**MEASURE POS:** Set the measuring position to **ORAL**, **AXILLARY** or **RECTAL**.

**Low Temp. Mode:** Activate /deactivate the Low Temp. Mode.

**NOTE:**

- 1 **The QUICK PREDICT mode is for oral measurement only.**
- 2 **Low Temp. Mode can be activated only when measure mode is PREDICT.**
- 3 **Make sure all settings of TEMP Setup are properly set up every time before you withdraw the probe from the probe well. If you modify the settings immediately a measurement is completed, the new settings will be effective for the next measurement.**

## 15.2 Infrared TEMP with TAT Thermometer

Exergen TAT-5000S TEMP module is compatible.

For TAT-5000S details, please refer to the corresponding manufacturer's manual.

## 15.3 TEMP Module via E-Link

The monitor supports external TEMP module including HTD8808C and IR20b through E-Link. To Connect the available device to the monitor, please follow below steps:

1. Turn on the monitor and IR20b or HTD8808C.
2. Select the **System Setup > E-Link > Available Device** on the monitor.
3. Choose the name of IR20b or HTD8808C and Click **Connect** to pair the monitor and IR20b or HTD8808C.

For more operation and specification of HTD8808C TEMP and IR20b TEMP, please refer to the corresponding manufacturer's manual.



## Chapter 16 Recording

A thermal dot matrix recorder is used for the monitor and can support many recording types and output patient information, measurement data, review data waveform and so forth.



1	Recording indicator ON: recorder is in normal working; OFF: the monitor is powered off.
2	Paper feeding key: press this key to start or stop feeding recording paper without outputting anything on the paper
3	Paper outlet
4	Recorder door

### NOTE:

**It is suggested that the user should not use the recorder when the low battery displays, or the monitor may be turned off automatically.**

### 16.1 Starting and Stopping Recording

The applicable recording paper width is 49 mm~50 mm. To manually start/stop recording, click Record icon  in the related windows.

The recorder will stop recording in the following situations:

- The recording task is finished.

- No paper in the recorder.
- Malfunction stops the recorder from running properly.

## 16.2 Recorder Operations and Status Messages

### 16.2.1 Record Paper Requirement

Only standard thermosensitive record paper can be used: otherwise the recorder may not function, the recording quality may be poor, and the thermosensitive printhead may be damaged.

### 16.2.2 Proper Operation

- When the recorder is working, the record paper goes out steadily. Do not pull the paper outward with force: otherwise the recorder may be damaged.
- Do not operate the recorder without record paper.

### 16.2.3 Paper Out

When the **Recorder Out OF Paper** prompt is displayed, the recorder cannot start. Please insert record paper properly.

### 16.2.4 Replacing Paper

1. Pull outwards the upper arc part of the recorder casing to release the casing, shown in the following figure.



2. Insert a new roll of paper into the paper cassette, printing side facing upwards.
3. Ensure proper position and tidy margin.
4. Pull about 2 cm of the paper out, and close the recorder casing.

**NOTE:**

**Be careful when inserting papers. Avoid damaging the thermo-sensitive print head. Unless when inserting papers or shooting troubles, do not leave the recorder catch open.**

### 16.2.5 Removing Paper Jam

When the recorder functions or sounds improperly, you should open the recorder casing to check for a paper jam. Remove the paper jam in the following way:

- Cut the record paper from the feeding edge.
- Open the recorder casing.
- Re-insert the paper.

**NOTE:**

- 1 If the monitor is not configured with the recorder function, it will indicate Recorder Setup Needed after the Record button is pressed.**
- 2 Do not touch the thermo-sensitive print head when performing continuous recording.**

## Chapter 17 Data Store

### 17.1 Data Store

In ward round mode, storage data maximally contains the following information:		
Round record	Patient information, parameters data (SpO <sub>2</sub> , NIBP, TEMP, PR measurement data and custom parameters data), storage time, etc.	Minimum 20000 sets in internal storage
In spot-checking mode, storage data contains the following information:		
In internal storage, Minimum 20000 sets of spot-checking data for multiple patients		

### 17.2 Formatting the Internal Storage Device

To format the internal storage device, select **Menu > User Maintain > Data Store > Format Internal Storage Device**. Further confirmation is required.

**NOTE:**



- 1 As soon as the internal storage device is formatted, all the data will be cleared.**
- 2 You have no need to restart the monitor after formatting is successful. The internal storage device can be identified and loaded automatically.**
- 3 If formatting is failed, try again. Restart the monitor and retry the formatting, or contact the service personnel of the manufacturer if formatting is failed repeatedly.**

### 17.3 Viewing the Capacity of Internal Storage Device

click **Menu > User Maintain > Data Store** to view the capacity of internal storage device.

### 17.4 Exporting Data to Removable Storage Device

Before exporting, please connect the removable storage device to the CS-05 stand. In

**Review**, click  to select patient data as required, click **Export** icon  and input user maintain password to confirm the operation.

## Chapter 18 Using Battery

This monitor can run on disposable AA battery or rechargeable Lithium-ion battery, which ensures its uninterrupted operation even when AC power supply is interrupted. The battery recharges whenever the monitor is connected to the Stand part.

The Stand part can be used to charge the monitor only when Lithium-ion battery is used. It is forbidden to use the Stand to charge the monitor when AA battery is used. If the monitor is charged with AA battery, it will automatically shut down.

As shown in the table below, choose the appropriate battery for the device based on actual needs.

iM3s Host	AA alkaline battery: 3 or Rechargeable Lithium-ion battery, Model: ID1028: 1
CS-05 Stand	Rechargeable Lithium-ion battery: 1 (non-detachable)
CS-04 Stand	No battery

### 18.1 Battery Safety Information

#### **WARNING**

- 1 Before using the rechargeable lithium-ion battery (hereinafter called lithium battery), be sure to read the user manual and safety precautions thoroughly.**
- 2 The lithium battery can only be used for this device.**
- 3 The lithium battery can only be charged in this device.**
- 4 The cycle life of the lithium battery is 500 times. The service life of the lithium battery may shorten if it is used inappropriately. It is recommended to replace the lithium battery after 500 charge-discharge cycles, or it may cause safety risks such as heat and liquid leakage, and risks such as failure or decline of performance.**
- 5 Do not connect the positive (+) and negative (-) terminals with metal objects such as lead wire, which can result in short circuits.**
- 6 Do not reverse the lithium battery polarity.**

---

---

**WARNING**

---

---

- 7 Do not heat or throw the lithium battery into a fire.**
  - 8 Do not immerse, throw or wet the lithium battery in water, beverages or other liquids.**
  - 9 Do not use or leave lithium battery at high temperature (charging > 45 °C, discharging > 60 °C, such as in direct sunlight or in a very hot car), otherwise it may cause overheat, fire, malfunction to the lithium battery, shorten the service life of the lithium battery, or damage the lithium battery.**
  - 10 Do not place the lithium battery near microwave equipment or other cooking devices. If the lithium battery is heated or subjected to strong electromagnetic radiation, liquid leakage, heat, smoke, fire, etc. may occur.**
  - 11 Do not hit with a hammer, step on or throw or drop to cause strong shock.**
  - 12 Do not weld the lithium battery directly.**
  - 13 Do not use a lithium battery of other specifications.**
  - 14 Power off the device, remove and stop using the battery if abnormal heat, odor, discoloration, deformation or abnormal condition is detected during use, charge, or storage, or it may cause safety accidents such as heat, smoke, and fire.**
  - 15 Do not touch a leaking lithium battery. If the liquid leaked from the lithium battery gets into eyes, do not rub the eyes. Wash them well with clean water and see a doctor immediately.**
  - 16 When the device is running on lithium battery power, do not replace the lithium battery during operation of the device.**
  - 17 High internal temperature may also cause the lithium battery unable to be charged. Keep the device at room temperature and move it away from heat sources or out of direct sunlight. The lithium battery will resume charging when the temperature is within range again.**
  - 18 Lithium batteries should be charged, used and stored in places far away from static electricity.**
  - 19 Keep lithium batteries out of the reach of children.**
- 
-

**WARNING**

**20 Lithium batteries are hazardous waste. Do NOT dispose them together with house-hold garbage. At the end of their life hand the batteries over to the applicable collection points for the recycling of waste batteries. For more detailed information about recycling of this product or lithium batteries, please contact your local Civic Office, or the shop where you purchased the product.**











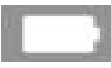

**21 Do not use a lithium battery with serious scratch or deformation.**



## 18.2 Battery Charging Indicator

The indicator on the front panel of the monitor is represented by a battery symbol. Lighting in yellow means charging; Lighting in green means full charge; Flashing in yellow means low battery.

## 18.3 Battery Status on the Main Screen

Battery status symbols show the status of each battery detected and the combined battery power remaining.

Battery status of the monitor		Battery status of the CS-05 Extended Stand	
	Remaining battery power: 76%~100%.		Remaining battery power: 76%~100%.
	Remaining battery power: 51%~75%		Remaining battery power: 51%~75%
	Remaining battery power: 26%~50%		Remaining battery power: 26%~50%
	Remaining battery power: 6%~25%		Remaining battery power: 6%~25%
	Remaining battery power: 5%. Prompt of battery low displays.		Remaining battery power: 5%. Prompt of battery low displays.
	Batteries are almost depleted and need to recharge immediately.		Batteries are almost depleted and need to recharge immediately.

Battery status of the monitor		Battery status of the CS-05 Extended Stand	
	Battery error		Battery error

## 18.4 Charging the Battery

To charge the battery, please follow the procedure:

1. Load the battery into the device and connect the device to the mains power. The battery indicator illuminates in yellow when battery is being charged.
2. Charge the battery until it is full, the battery indicator illuminates in green and the battery power indicator is filled.

### NOTE:

**It is recommended to charge the battery when the device is switched off so as to improve the charging efficiency and save charging time.**

## 18.5 Maintaining the Battery

The performance of rechargeable batteries may deteriorate over time. It is recommended to check and maintain the batteries regularly every 3 months.

1. Disconnect the patient from the device and stop all measurement.
2. Switch off the device, connect it to mains power, install the battery and fully charge it.
3. Disconnect the device from mains power, switch on the device and let the device run until there is no battery power left and the device shuts off.
4. Reconnect the device to mains power and charge the battery until it is full for use or charge to 40%~60% for storage.

### NOTE:

- 1 Do not use the device on a patient during the battery maintenance.**
- 2 Do not interrupt the battery maintenance process.**

## 18.6 Storing the Battery

Remove the lithium battery and store it at a cool and dry environment if the lithium battery or the device is not used for a long time. Charge the batteries to 40%-60% for



storage. Check and maintain the batteries regularly every 3 months. For more information, please refer to Section *Maintaining the Battery*.

**NOTE:**

- 1 When storing batteries, make sure that the battery terminals do not come into contact with metallic objects.**
- 2 The service life of the battery will be shortened if it is stored at high temperature for a long time. Storing batteries in a cool place can slow down the aging process. The ideal storage temperature is 15 °C.**

## 18.7 Checking Battery Performance

The performance of rechargeable batteries may deteriorate over time. If you suspect that the battery may have failed, check the battery performance.

Refer to Step 1~Step 3 in Section *Maintaining the Battery* and record the running time of the battery which reflects the battery performance directly. If the running time is obviously less than the specified time in the specification, the battery may have reached its service life or malfunctioned, please change the battery or contact the service personnel. If the running time meets the specification, then the battery can continue to be used normally.

## 18.8 Recycling the Battery

When the battery no longer holds a charge, it should be replaced. Remove the old battery from the monitor and recycle it properly.

---

---

**WARNING**

**Do not disassemble batteries, put them into fire or cause them to short circuit. They may ignite, explode or leak, causing personal injury.**

---

---

## 18.9 Replacing the Battery

To install or replace the battery, please follow the procedure:

Lithium-ion battery

1. Push the battery latch down according to icon indication.
2. Grab the handle on the bottom of battery to pull battery out.

3. Insert the new battery into the battery compartment.
4. Place the metal terminal of the new battery to right-front, and close to the front end of the groove (as shown below). Gently press it (do not push battery from back to front) until the battery is fully installed in the groove.

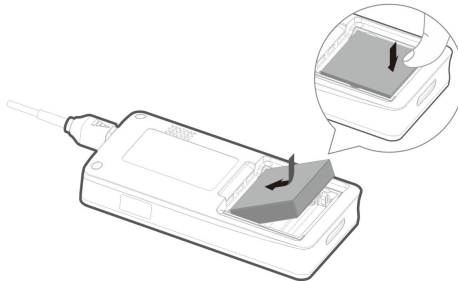

5. Place the bottom of battery door at the bottom of groove. Gently press battery door and bolt up the latch to close the door.

#### AA battery

Please follow the positive and negative direction in the groove to install battery.

Use the battery with similar performance, which can extend the service life of the battery. If one of the two batteries is malfunctioning, it is recommended to change both of the two batteries.

## Chapter 19 Care and Cleaning

Use only the EDAN-approved substances and methods listed in this chapter to clean or disinfect your equipment. Warranty does not cover damage caused by using unapproved substances or methods.

EDAN Instruments has validated the cleaning and disinfection instructions included in this User Manual. It is the responsibility of the healthcare professional to ensure that the instructions are followed so as to ensure adequate cleaning and disinfection.

### 19.1 Safety Instructions

#### Reusable products

Reusable products must be reprocessed, otherwise there is an increased risk of infection.

- ▶ Follow the infection prevention policies and reprocessing regulations of the health-care facility.
- ▶ Follow the national infection prevention policies and reprocessing regulations.
- ▶ Use validated procedures for reprocessing.
- ▶ Reprocess reusable products after every use.
- ▶ Follow the manufacturer's instructions for cleaning agents, disinfectants, and reprocessing devices. Signs of wear, e.g., cracks, deformation, discoloration, or peeling, may occur with reprocessed products.
- ▶ Check the products for signs of wear and replace them if necessary.

#### Disposable products

Disposable products have been designed, tested, and manufactured exclusively for single use. Reuse, reprocessing, or sterilization can result in failure of the accessory, incorrect measurements, and injury to the patient.

- ▶ Do not reuse disposable products.
- ▶ Do not reprocess disposable products.
- ▶ Do not use any disinfectants.

### 19.2 General Points

Keep your monitor, cables and accessories free of dust and dirt. To prevent the device

from damage, please follow the procedure:

- Use only recommended cleaning substances and disinfectants listed in this manual. Others may cause damage (not covered by warranty), reduce product lifetime or cause safety hazards.
- Always dilute according to the manufacturer's instructions.
- Unless otherwise specified, do not immerse any part of the equipment or any accessories in liquid.
- Do not pour liquid onto the system.
- Do not allow liquid to enter the case.
- Never use abrasive material (such as steel wool or silver polish).
- Do not wet the pins or metal parts of the main unit or accessories during cleaning and disinfection.
- Inspect the monitor and reusable accessories after they are cleaned and disinfected.

---

### **CAUTION**

---

**If you spill liquid on the equipment, battery, or accessories, or they are accidentally immersed in liquid, contact your service personnel or EDAN service engineer.**

---

#### **NOTE:**

**Automated cleaning/disinfection to the equipment and accessories is prohibited.**

### **19.3 Cleaning**

If the device or accessory has been in contact with the patient, then cleaning and disinfection is required after every use. If there has been no patient contact and there is no visible contamination then daily cleaning and disinfection is appropriate.

The validated cleaning agents for cleaning the monitor and reusable accessories are:

1. Mild near neutral detergent
2. Ethanol (75%)
3. Isopropanol (70%)

Cleaning agents should be applied and removed by using a clean cotton swab or a clean, soft, non-abrasive cloth or paper towel each time. Refer to the cleaning agent manufacturer's instruction for use with reference to concentration, temperature and contact time.

### 19.3.1 Cleaning the Monitor

---

---

#### **WARNING**

**Before cleaning the monitor, make sure that the monitor is switched off and disconnected from the power line.**

---

---

To surface-clean the monitor, follow these steps:

1. Switch off the monitor and disconnect it from the power line.
2. Disassemble the host from the charger stand, and then disassemble the protection cover from the host.
3. Remove all residual foreign matters from the surface of the charger stand and the host using sterile cloth or paper towel immediately after examination until the surface is visually clean.
4. Use a clean cotton swab dampened with the cleaning solution to wipe the surface apertures of the equipment, including the host, the protection cover and the charger stand until no visible contaminants remain.
5. Use a soft clean cloth dampened with the cleaning solution to wipe the entire exterior surface of the equipment, including the host, the protection cover and the charger stand until no visible contaminants remain.
6. After cleaning, wipe off the cleaning solution with a fresh cloth or towel dampened with tap water until no visible cleaning agent remains.
7. Dry the host, the protection cover and the charger stand in a ventilated and cool place.
8. If the host, the protection cover or the charger stand is not visually clean at the end of the cleaning steps, please repeat the cleaning steps through step 4 to step 7.
9. Inspect the host, the protection cover or the charger stand to ensure that there is no damage.

10. Reassemble the protection cover to the host, and then reassemble the host with the protective cover to the charger stand.

## 19.3.2 Cleaning the Reusable Accessories

### 19.3.2.1 Cleaning the Blood Pressure Cuff

#### **Cleaning the Cuff:**

1. Disassemble NIBP Cuff from the monitor, and take out the air bladder.
2. Remove all residual foreign matters from the surface of cuff and air bladder using sterile cloth or paper towel immediately after examination until the surface is visually clean.
3. Hand wash the cuff with the cleaning solution; clean the air bladder with a soft cloth dampened with the cleaning solution. Clean the surface of the cuff and the air bladder thoroughly until no visible contaminants remain
4. Rinse the cuff and after cleaning, wipe off the cleaning solution with a fresh cloth or towel dampened with tap water until no visible cleaning agent remains.
5. Wipe off residual moisture with a dry cloth.
6. Air dry the cuff thoroughly after cleaning.
7. If the cuff and the air bladder are not visually clean at the end of the cleaning steps, please repeat the cleaning steps through step 3 to step 6.
8. Inspect the cuff and the air bladder to ensure that there is no damage.

#### **Replacing the Air Bladder:**

After cleaning, replace the air bladder into the cuff following the steps below:

1. Roll the bladder lengthwise and insert it into the cuff from the large opening at one end of the cuff.
2. Thread the hose from within the cuff and out through the small hole at the top of the cuff.
3. Adjust the bladder until it is in position.

### 19.3.2.2 Cleaning the SpO<sub>2</sub> Sensor

1. Disassemble SpO<sub>2</sub> sensor from the monitor.

2. Remove all residual foreign matters from the surface of SpO<sub>2</sub> Sensors, including cables, using sterile cloth or paper towel immediately after examination until the surface is visually clean.
3. Wipe the surfaces of the sensor and cable using a soft cloth dampened with the cleaning solution until no visible contaminants remain.
4. Wipe the patient contact area of the sensor with the cotton swab dampened with the cleaning solution. until no visible contaminants remain
5. After cleaning, wipe off the cleaning solution with a fresh cloth or towel dampened with tap water until no visible cleaning agent remains.
6. Wipe off residual moisture with a dry cloth.
7. Leave the sensor to air dry.
8. If the SpO<sub>2</sub> Sensors, including cables, are not visually clean at the end of the cleaning steps, please repeat the cleaning steps through step 3 to step 7.
9. Inspect the SpO<sub>2</sub> Sensors, including cables, to ensure that there is no damage.

#### 19.3.2.3 Cleaning the TEMP Sensor

1. Disassemble quick TEMP module from the monitor.
2. Remove all residual foreign matters from the surface of TEMP Sensors using sterile cloth or paper towel immediately after examination until the surface is visually clean.
3. Wipe the sensor with a soft cloth dampened with the cleaning solution until no visible contaminants remain.
4. After cleaning, wipe off the cleaning solution with a fresh cloth or towel dampened with tap water until no visible cleaning agent remains.
5. Wipe off residual moisture with a dry cloth.
6. Leave the sensor/probe to air dry.
7. If the TEMP Sensors are not visually clean at the end of the cleaning steps, please repeat the cleaning steps through step 3 to step 6.
8. Inspect the TEMP Sensors to ensure that there is no damage.

## 19.4 Disinfection

For devices or accessories that have been in contact mucosal surface, High Level disinfection must occur, for all other accessories, low level disinfection is appropriate. Clean the monitor and reusable accessories before they are disinfected. The validated disinfectants for disinfecting the monitor and reusable accessories are:

- Ethanol (75%)
- Isopropanol (70%)

Disinfecting agents should be applied and removed by using a clean cotton swab or a clean, soft, non-abrasive cloth or paper towel each time. Refer to the disinfecting agent manufacturer's instruction for use with reference to concentration, temperature and contact time.

---

---

### **CAUTION**

- 1 Do not use any disinfectant containing additional active ingredients other than those listed, such as disinfectant didecyl dimethyl ammonium bromide which contains quaternary ammonium salt.**
- 2 Although the monitor chemically resistant to most common hospital cleaners, disinfectants and non-caustic detergents, unvalidated cleaners or disinfectants are not recommended and may stain the monitor, such as disinfectant didecyl dimethyl ammonium bromide which contains quaternary ammonium salt.**
- 3 Do not use phenol disinfectants because vinyl absorbs them. Do not use strong aromatic, chlorinated, ketone, ether or ester solvents. Do not immerse the cables for any prolonged period in alcohol, mild organic solvents, or highly alkaline solutions. Never boil or autoclave the cable. Vinyl withstands temperatures up to 100 °C but begins to soften at around 90 °C. Handle gently when hot and wipe away from the tip toward the cable.**

---

---

### **WARNING**

**The monitor and reusable accessories shall be disinfected to avoid patient cross infection.**

---

---



## 19.4.1 Disinfecting the Monitor

---

---

### **WARNING**

**Before disinfecting the monitor, make sure that the monitor is switched off and disconnected from the power line.**

---

---

To disinfect the monitor, follow these steps:

1. Switch off the monitor and disconnect it from the power line.
2. Disassemble the host from the charger stand, and then disassemble the protection cover from the host.
3. Clean and dry the monitor, including the charger stand, the host and the protection cover, according to the methods in section *Cleaning the Monitor* prior to disinfection.
4. Prepare the disinfectant solution.
5. Use a clean cotton swab dampened with the disinfectant solution to wipe the surface apertures of the equipment, including the host, the protection cover and the charger stand. Follow the disinfectant manufacture's recommended contact time and mode.
6. Use a soft clean cloth dampened with the disinfectant solution to wipe the entire exterior surface of the equipment, including the host, the protection cover and the charger stand. Follow the disinfectant manufacture's recommended contact time and mode.
7. After disinfection, wipe off the disinfecting agent with a new sterile cloth dampened with sterile water.
8. Dry the host, the protection cover and the charger stand for at least 30 minutes in a ventilated and cool place.
9. Inspect the host, the protection cover or the charger stand to ensure that there is no damage.
10. Reassemble the protection cover to the host, and then reassemble the host with the protective cover to the charger stand.

## 19.4.2 Disinfecting the Reusable Accessories

### 19.4.2.1 Disinfecting the Blood Pressure Cuff

#### **Disinfecting the Cuff:**

1. Disassemble NIBP Cuff from the monitor, and take out the air bladder.
2. Clean and dry the NIBP Cuff and air bladder according to the methods in section *Cleaning the Blood Pressure Cuff* prior to disinfection.
3. Prepare the disinfectant solution.
4. Wipe the cuff and the air bladder with a soft cloth dampened with the disinfectant solution.
5. Leave the cuff and air bladder to air dry for at least 30 minutes.
6. Inspect the cuff and the air bladder to ensure that there is no damage.

#### **Replacing the Air Bladder:**

After disinfection, replace the air bladder into the cuff. Refer to Section *Cleaning the Blood Pressure Cuff* for more information.

#### **NOTE:**

**Prolonged use of disinfectant may cause discoloration of the cuff.**

### 19.4.2.2 Disinfecting the SpO<sub>2</sub> Sensor

1. Disassemble the SpO<sub>2</sub> sensor from the monitor.
2. Clean and dry the SpO<sub>2</sub> sensor according to the methods in section *Cleaning the SpO<sub>2</sub> Sensor* prior to disinfection.
3. Prepare the disinfectant solution.
4. Wipe the surfaces of the sensor and cable using a soft cloth dampened with the disinfection solution.
5. Wipe the patient contact area of the sensor with the cotton swab dampened with the disinfection solution.
6. Wipe off the disinfection solution with a dry cloth after disinfection.
7. Leave the sensor to air dry for at least 30 minutes.
8. Inspect the SpO<sub>2</sub> Sensor, including the cable, to ensure that there is no damage.

### 19.4.2.3 Disinfecting the TEMP Sensor

The intracavitary TEMP sensors should be reprocessed by high-level disinfection before and after use on each new patient. Cidex OPA is the validated agent for high level disinfection. Refer to the instructions of the disinfectant for the methods of disinfection. High level disinfection has been validated with a 12 minute soak. Rinse and dry according to the labeled instructions of Cidex OPA. Do not dampen the sensor connector.

For the skin TEMP sensors, disinfect them as follows using ethanol or isopropanol only:

1. Disassemble quick TEMP module from the monitor.
2. Clean and dry the TEMP Sensor according to the methods in section *Cleaning the TEMP Sensor* prior to disinfection.
3. Prepare the disinfectant solution.
4. Wipe the sensor with a soft cloth dampened with the disinfectant solution (ethanol or isopropanol).
5. Wipe off the disinfectant solution with a dry cloth after disinfection.
6. Leave the sensor to air dry.
7. Inspect the TEMP Sensor, to ensure that there is no damage.

## 19.5 Cleaning and Disinfecting Other Accessories

For cleaning and disinfecting other accessories, refer to the instructions delivered with the accessories. If the accessories are not accompanied by instructions, refer to this manual for the methods of cleaning and disinfecting the monitor.

## 19.6 After Reprocessing

- After reprocessing, the equipment, cables, cuffs, sensors and other accessories should be checked to ensure there are no signs of aging, wear, cracks, deformation, discoloration or peeling, etc. Replacement should be taken or contact the service personal of the manufacturer if necessary.
- Assembling and attaching device-specific components

Prerequisite:

All components have been reprocessed and are dry.

➤ Preparation before next use of device

Assembling and fitting patient-specific accessories and consumables, i.e. SpO<sub>2</sub> sensors and NIBP Cuffs.

## 19.7 Storage and Transport

After reprocessing, there are no special requirements for storage and transport of the product. However, the following must be observed:

- Store dry and free of dust
- Avoid recontamination and damage during transport

All further information on storage and transport included in the accompanying documents must be observed.

## Chapter 20 Maintenance

---

---

### **WARNING**

- 1 Failure on the part of the responsible individual hospital or institution employing the use of this equipment to implement a satisfactory maintenance schedule may cause undue equipment failure and possible health hazards.**
  - 2 If you discover a problem with any of the equipment, contact your service personnel, or your authorized supplier.**
  - 3 The maintenance operations like software upgrade of the device can only be completed by EDAN-qualified service professionals. The history data in monitor may be deleted due to software upgrade. Before software upgrade, please backup the data in the monitor to avoid data loss.**
  - 4 Any serious incident that has occurred in relation to the device should be reported to the manufacturer and the competent authority of the Member State in which the user and/or patient is established.**
- 
- 

### 20.1 Inspecting

The overall check of the monitor, including the safety check, should be performed only by qualified personnel every 24 months, and each time after fix up.

The following items should be checked:

- If the environment condition and power supply meet requirement.
- If the power supply cord has damage and insulativity meets requirement.
- If the device and accessories have damage.
- Specified accessories.
- If the recorder can work properly and the paper meets the requirement.
- Battery performance
- If all functions are in good conditions.
- If the grounding resistance and leakage current meet requirement.

If any damage or abnormality is found, please don't use the monitor and contact local Customer Service Center.

## 20.2 Maintenance Task and Test Schedule

Maintenance shall be carried out at least once every two years, or as specified by local regulations. The following tasks are for EDAN-qualified service professionals only. Contact an EDAN-qualified service provider if your monitor needs a safety or performance test. Clean and disinfect equipment to decontaminate it before testing or maintaining it.

Maintenance and Test Schedule	Frequency
Safety checks. Selected tests on the basis of IEC60601-1	At least once every two years, or as needed, after any repairs where the power supply is removed or replaced, or if the monitor has been dropped.
Check all monitoring functions and measuring functions	At least once every two years, or as needed.

## Chapter 21 Warranty and Service

### 21.1 Warranty

EDAN warrants that EDAN's products meet the labeled specifications of the products and will be free from defects in materials and workmanship that occur within warranty period.

The warranty is void in cases of:

- a) damage caused by mishandling during shipping.
- b) subsequent damage caused by improper use or maintenance.
- c) damage caused by alteration or repair by anyone not authorized by EDAN.
- d) damage caused by accidents.
- e) replacement or removal of serial number label and manufacture label.

If a product covered by this warranty is determined to be defective because of defective materials, components, or workmanship, and the warranty claim is made within the warranty period, EDAN will, at its discretion, repair or replace the defective part(s) free of charge. EDAN will not provide a substitute product for use when the defective product is being repaired.

#### NOTE:



**The products marked with this symbol apply to the European WEEE directive. This symbol indicates this equipment contains electrical or electronic components that must not be disposed of as unsorted municipal waste, but collected separately. Contact an authorized representative of the manufacturer for information for the decommissioning of your equipment.**

### 21.2 Contact Information

If you have any question about maintenance, technical specifications or malfunctions of devices, contact your local distributor.

Alternatively, you can send an email to EDAN service department at: [support@edan.com](mailto:support@edan.com).

## Chapter 22 Accessories

You can order accessories from EDAN supplies at [www.edan.com](http://www.edan.com) or consult your local EDAN representative for details.

### **WARNING**

- 1 Never reuse disposable transducers, sensors, accessories and so forth that are intended for single use, or single patient use only. Reuse may compromise device functionality and system performance and cause a potential hazard.**
- 2 Use only EDAN-approved accessories. Using non-EDAN-approved accessories may compromise device functionality and system performance and cause a potential hazard. It is not recommended to use accessories supplied by EDAN with patient monitors by other manufacturers.**

### **NOTE:**

**Transducers and sensors have a limited shelf life. Refer to the package labeling.**

The following cables may not all be available in all countries. Please check availability with your local EDAN supplier.

### 22.1 SpO<sub>2</sub> Accessories

Part Number	Accessories
02.57.225039	SH1 SpO <sub>2</sub> Finger Sensor, adult, 1 m, reusable
01.57.471405	SHEC5 SpO <sub>2</sub> Extension cable
02.01.210122	SH4 Adult Silicone Soft-tip SpO <sub>2</sub> Sensor
02.01.210121	SH5 pediatric Silicone Soft-tip SpO <sub>2</sub> Sensor
02.01.210673	SH3 Neonate Wrap SpO <sub>2</sub> Sensor
02.01.210120	SpO <sub>2</sub> Finger Sensor, adult, 1 m, reusable
01.57.471235	SpO <sub>2</sub> Sensor, adult, 0.5 m, disposable, with EDAN logo



Part Number	Accessories
01.57.471236	SpO <sub>2</sub> Sensor, pediatric, 0.5 m, disposable, with EDAN logo
01.57.471237	SpO <sub>2</sub> Sensor, Infant, 0.5 m, disposable, with EDAN logo
01.57.471238	SpO <sub>2</sub> Sensor, Neonate, 0.5 m, disposable, with EDAN logo
02.57.225000	SpO <sub>2</sub> Sensor, Ear Clip, Adult/Pediatric, 1 m, reusable

## 22.2 NIBP Accessories

Part Number	Accessories
01.57.471908	NIBP cuff, BPT3, extension tube
01.57.471331	NIBP Cuff, Large adult E10, 34 cm–43 cm, reusable
01.57.471329	NIBP Cuff, Small adult E8, 20.5 cm–28 cm, reusable
01.57.471328	NIBP Cuff, Child E7, 16 cm–21.5 cm, reusable
01.57.471327	NIBP Cuff, Small child E6, 13 cm–17 cm, reusable
01.57.471326	NIBP Cuff, Infant E5, 10 cm–15 cm, reusable
01.57.471323	NIBP Cuff, Neonate, 10 cm–15 cm, reusable
01.57.471324	NIBP Cuff, Neonate, 6 cm–11 cm, reusable
01.57.471157	Single Patient Use NIBP Cuff, neonatal #1, 3 cm–6 cm, soft disposable 98-0400-99
01.57.471158	Single Patient Use NIBP Cuff, neonatal #2, 4 cm–8 cm, soft disposable 98-0400-96
01.57.471159	Single Patient Use NIBP Cuff, Model DC100, neonatal #3, 6 cm–11 cm, soft disposable 98-0400-97
01.57.471160	Single Patient Use NIBP Cuff, neonatal #4, 7 cm–13 cm, soft disposable 98-0400-98

Part Number	Accessories
01.57.471161	Single Patient Use NIBP Cuff, neonatal #5, 8 cm-15 cm, soft disposable 98-0400-90
01.57.471330	NIBP Cuff, Adult, 27cm-35cm, reusable

## 22.3 TEMP Accessories

Part Number	Accessories
F3000 TEMP	
01.57.471312	Filac 3000 Thermometer Probe, Oral/Axillary with 4' (1.2 m) Cord, 500026
01.57.471313	Filac 3000 Thermometer Probe, Oral/Axillary with 9' (2.7 m) Cord, 500027
02.01.210848	F3000 Probe Cover (20 pcs/box, 25 boxes/kit)
02.01.210849	F3000 Probe Cover (20 pcs/box, 100 boxes/kit)
01.22.066159	Filac 3000 Isolation Chamber, Oral/Axillary, 500028
01.57.471314	Filac 3000 Thermometer Probe, Rectal with 4' (1.2 m) Cord, 500036
01.57.471315	Filac 3000 Thermometer Probe, Rectal Probe with 9' (2.7 m) Cord, 500037
01.22.066160	Filac 3000 Isolation Chamber, Rectal, 500038
01.57.471316	Filac 3000 Probe Covers Coiffes pour sonde 502000
01.51.413192	F3000 Isolation Chamber (blue)
01.51.413270	F3000 Isolation Chamber (red)
IR20b TEMP	
01.57.472645	Ear Thermometer

Part Number	Accessories
01.57.472646	Ear Thermometer Probe Cover

## 22.4 Other Accessories

Part Number	Accessories
01.21.064397	Rechargeable Li-ion Battery Pack, ID1028, 1ICP6/47/40-2, 3.8 V, 2800 mAh
01.51.412666	Protection cover for monitor
01.13.036638	Power cable, European standard
01.13.037122	Power cable, American standard
01.13.038197	Power Cord (US) (only applicable for wall mounting bracket)
01.57.78035	Recorder paper
02.04.101976	Rolling Stand Basket (in the bottom)
83.60.262072	MT-206 (S) Trolley
02.04.246146	iM3s Trolley Adaptor Kit
01.21.064086	Disposable AA battery, Alkaline LR6, 1.5V, 2600 mAh
01.52.433532	CS04&CS05 base main bracket
01.52.433533	CS04&CS05 base main bracket connector
01.52.432600	CS-05 front fixing bracket

**NOTE:**

The part name may vary depending on context, but the part number is constant.

## A Product Specification

### NOTE:

- 1 The performance of the equipment with ☆ mark is determined to be essential performance.
- 2 For the specification of TEMP module via E-Link, please refer to the corresponding manufacturer's manual.

### A.1 Classification

Anti-electroshock type	Class I equipment and internal powered equipment
Anti-electroshock degree	SpO <sub>2</sub> , NIBP: CF (DEFIBRILLATION-PROOF) TEMP: BF (NON-DEFIBRILLATOR PROOF)
Ingress Protection	Monitor: IP44 (protected against splashing water and solid foreign objects ≥ 1.0 mm diameter) CS-04 Charger Stand: IPX1 (Protected against vertically falling water drops) CS-05 Extended Stand: IPX1 (F3000 TEMP have no ingress protection)
Disinfection/sterilization method	Refer to Chapter <i>Care and Cleaning</i> for details.
Working system	Continuous operation equipment
Compliant with Standards	IEC 60601-1; IEC 60601-1-2; EN ISO 80601-2-56; EN 60601-1; EN 60601-1-2; EN 80601-2-30; EN ISO 80601-2-61; IEC 80601-2-49

### A.2 Physical Specifications

#### A.2.1 Size and Weight

Size (monitor)	(77±1) mm (W) × (150±1) mm (H) × (28±1) mm (D)
----------------	--

Weight (monitor)	<p>&lt; 300 g (standard configuration, without battery and accessories)</p> <p>&lt; 350 g (standard configuration, with rechargeable battery, without accessories)</p> <p>&lt; 370 g (standard configuration, with AA battery, without accessories)</p>
Size (CS-04 Charger Stand)	(165±1) mm (L) × (113±1) mm (W) × (164±1) mm (H)
Size (CS-05 Extended Stand)	(165±1) mm (L) × (113±1) mm (W) × (164±1) mm (H)
Weight (CS-04 Charger Stand)	< 900 g
Weight (CS-05 Extended Stand)	< 2000 g (including recorder, not including TEMP module and accessories)

## A.2.2 Function Configuration

Product	Configuration
iM3s	<ul style="list-style-type: none"> <li>• EDAN SpO<sub>2</sub>, EDAN NIBP;</li> <li>• AA battery</li> <li>• F3000 TEMP, TAT-5000S TEMP, IR20b TEMP;</li> <li>• Built-in barcode scanner, Wi-Fi, rechargeable battery, CS-04 Charger Stand, CS-05 Extended Stand, Recorder</li> </ul>
iM3As	<ul style="list-style-type: none"> <li>• EDAN SpO<sub>2</sub>, EDAN NIBP;</li> <li>• AA battery</li> <li>• F3000 TEMP, TAT-5000S TEMP, IR20b TEMP;</li> <li>• Built-in barcode scanner, Wi-Fi, rechargeable battery, CS-04 Charger Stand, CS-05 Extended Stand, Recorder</li> </ul>
iM3Bs	<ul style="list-style-type: none"> <li>• EDAN SpO<sub>2</sub>, EDAN NIBP;</li> <li>• AA battery</li> </ul>

Product	Configuration
	<ul style="list-style-type: none"> <li>F3000 TEMP, TAT-5000S TEMP, IR20b TEMP;</li> <li>Built-in barcode scanner, Wi-Fi, rechargeable battery, CS-04 Charger Stand, CS-05 Extended Stand, Recorder</li> </ul>
iHM3s	<ul style="list-style-type: none"> <li>EDAN SpO<sub>2</sub>, EDAN NIBP;</li> <li>AA battery</li> <li>F3000 TEMP, TAT-5000S TEMP, IR20b TEMP;</li> <li>Built-in barcode scanner, Wi-Fi, rechargeable battery, CS-04 Charger Stand, CS-05 Extended Extended Stand, Recorder</li> </ul>

### A.2.3 Environment Specification

The monitor may not meet the performance specifications given here if stored or used outside the specified temperature and humidity ranges.

When the monitor and related products have differing environmental specifications, the effective range for the combined products is that range which is common to the specifications for all products.

Temperature	
Working	+0 °C to +40 °C (32 °F ~104 °F)
Transport and Storage	-20 °C to +55 °C (-4 °F ~131 °F)
Humidity	
Working	15%RH ~ 95%RH (non-condensing)
Transport and Storage	15%RH ~ 95%RH (non-condensing)
Altitude	
Working	86 kPa ~ 106 kPa
Transport and Storage	70 kPa ~ 106 kPa

CS-04 Charger Stand	
Power Supply	100 V-240 V, 50 Hz/60 Hz
	Current: 0.5 A-0.25 A (MAX), with the overcurrent fusing protection
CS-05 Extended Stand	
Power Supply	100 V-240 V, 50 Hz/60 Hz
	Current: 0.5 A-0.3 A (MAX), with the overcurrent fusing protection

## A.2.4 Display

Display	5-inch color screen
Touch screen	capacitive
Resolution	720×1280
Display information	<ul style="list-style-type: none"> <li>Power-on/Prompt Indicator/Standby Indicator</li> </ul> <p>When starting up, the indicator flashes once in order of three colors;</p> <p>When prompt occurs, the indicator keeps lighting in blue.</p> <p>When Standby indicator is turned on, the indicator lights in blue in standby mode.</p>
	<ul style="list-style-type: none"> <li>Charging Indicator on top right of the monitor panel</li> </ul> <p>Lighting in yellow means charging;</p> <p>Lighting in green means full charge;</p> <p>Flashing in yellow means low battery;</p> <p>Indicator off in charging process means charging fault.</p>

## A.2.5 Battery Specification

### Battery of the monitor

Number	AA battery: 3
	Lithium-ion battery: 1
Battery Type	Disposable AA battery or rechargeable Lithium-ion battery

Capacity	AA battery: 3*1.5 V Lithium-ion battery: 3.8 V; $\geq 2700$ mAh	
Charge/discharge cycle	500 times	
Operating Time	AA battery	Standby $\geq 10$ hrs Normal working status: $\geq 6$ hrs
	Lithium-ion battery	Standby $\geq 12$ hrs Normal working status: $\geq 8$ hrs
Charging Time (Lithium-ion battery)	$\leq 14$ hrs, the monitor is on or in standby mode	
Fast Charging Time (Lithium-ion battery)	$< 4$ hrs, when the monitor is off	

#### Battery of the CS-05 Extended Stand

Number	1
Battery Type	Rechargeable Lithium-ion battery
Capacity	10.8 V; 2400 mAh
Operating Time	without external modules used: $\geq 20$ hrs with external modules used : $\geq 8$ hrs
Fast Charging Time	$< 3.5$ hrs, in OFF status, not connected with monitor, and only provides charging function for the Stand.

### A.3 NIBP

Technique	Oscillometry
Mode	Manual, Continuous, Average



Continuous	5 min, interval is 5 s	
Measuring Parameter	SYS, DIA, MAP, PR	
Pressure Unit	kPa, mmHg	
Average measurement	Interval (unit: minutes)	1/2/3/4/5
	Times	3/5
☆Measuring Range		
☆Adult Mode	SYS: 25 mmHg to 290 mmHg DIA: 10 mmHg to 250 mmHg MAP: 15 mmHg to 260 mmHg	
☆Pediatric Mode	SYS: 25 mmHg to 240 mmHg DIA: 10 mmHg to 200 mmHg MAP: 15 mmHg to 215 mmHg	
☆Neonatal Mode	SYS: 25 mmHg to 140 mmHg DIA: 10 mmHg to 115 mmHg MAP: 15 mmHg to 125 mmHg	
☆Cuff Pressure Measuring Range	0 mmHg to 300 mmHg	
Pressure Resolution	1 mmHg	
☆Maximum Mean Error	±5 mmHg	
☆Maximum Standard Deviation	8 mmHg	
Maximum Measuring Period		
Adult/Pediatric	120 s	
Neonate	90 s	
Typical Measuring Period	30 s to 45 s (depend on HR/motion disturbance)	
Dual Independent Channel Overpressure Protection		
Adult	(297±3) mmHg	

Pediatric	(245±3) mmHg
Neonatal	(147±3) mmHg
Pre-inflation Pressure	
Adult Mode	Default: 160 mmHg Range: Auto/80/100/120/140/150/160/180/200/220/240 mmHg
Pediatric Mode	Default: 140 mmHg Range: Auto/80/100/120/140/150/160/180/200 mmHg
Neonatal Mode	Default: 100 mmHg Range: Auto/60/70/80/100/120 mmHg

#### A.4 SpO<sub>2</sub>

Measuring Range	0% to 100%
Resolution	1%
☆Data Update Period	1 s
☆Accuracy	
☆Adult /Pediatric	±2% (70% to 100% SpO <sub>2</sub> )
	Undefined (0% to 69% SpO <sub>2</sub> )
☆Neonate	±3% (70% to 100% SpO <sub>2</sub> )
	Undefined (0% to 69% SpO <sub>2</sub> )
SpO <sub>2</sub> Storage Interval	In round or spot-checking mode 30 S (default), 1 min, 2 mins, 5 mins
Sensor	
Red Light	(660±3) nm
Infrared Light	(905±10) nm
Emitted Light Energy	< 15 mW

PI	
Measuring Range	0-10, invalid PI value is 0.
Resolution	1

**NOTE:**

The information about wavelength range can be especially useful to clinicians (for instance, when photodynamic therapy is performed).

**A.5 PR**

	Measuring range	Accuracy	Resolution
PR (SpO <sub>2</sub> )	25 bpm to 300 bpm	±2 bpm	1 bpm
PR (NIBP)	40 bpm to 240 bpm	±3 bpm or 3.5%, whichever is greater	1 bpm

**A.6 TEMP**

## F3000 Module

☆Measuring range	30 °C~43 °C
Prediction measurement range	35 °C~43 °C
Low Temp. Mode prediction measurement range	33 °C~43 °C
Working temperature	10 °C ~ 40 °C
Transport and Storage	-20 °C ~ 55 °C
Sensor type	Oral /axillary /rectal
Resolution	0.1 °C
☆Accuracy	Monitoring Mode and Predictive Mode: ±0.1 °C (±0.18 °F) Quick Predictive Mode: ±0.3 °C (±0.54 °F)
Typical measurement time (after insertion into	Oral (Quick Predictive Mode): (3~5) s (non-fever temps); (8~10) s (fever temps)

measurement site)	Oral (Predictive Mode): (6~10) s
	Axillary: (8~12) s
	Rectal: (10~14) s
	Monitoring Mode (all sites): (60~120) s
Measuring Mode	Direct Mode /Adjusted Mode
Transient Response Time	≤30 s monitoring mode
Clinical Bias	(-0.2 to -0.4) °C
Limits of Agreement	0.49
Stability	0.14 °C

**NOTE:**

**The direct mode refers to monitor mode, while adjusted mode refers to predictive mode and quick predictive mode.**

## A.7 Wi-Fi

Radio Technology	802.11 a/b/g/n
Frequency Range	FCC: 2412 MHz ~ 2462 MHz, 5180 MHz ~ 5825 MHz CE: 2412 MHz ~ 2472 MHz, 5180 MHz ~ 5825 MHz
Modulation	DBPSK, DQPSK, CCK, BPSK, QPSK, 16-QAM, 64-QAM
Output power	<20 dBm (CE requirement: detection mode - RMS) <30 dBm (FCC requirement: detection mode - peak power)
Transmit rate	IEEE 802.11b: 1 Mbps to 11 Mbps IEEE 802.11g: 6 Mbps to 54 Mbps IEEE 802.11n: 6.5 Mbps to 72.2 Mbps IEEE 802.11a: 6 Mbps to 54 Mbps
Bandwidth	2.4 GHz & 5 GHz 20 MHz

## A.8 E-Link

Radio Technology	BR, EDR, BLE
Frequency Range	2402 MHz ~ 2480 MHz
Modulation	GFSK, $\pi/4$ -DQPSK, 8-DPSK
Output power	<20 dBm
Transmit rate	Classic: 1 Mbps, 2 Mbps, 3 Mbps BLE: 1 Mbps
Bandwidth	Classic: 1 MHz BLE: 2 MHz

## A.9 USB Interface

USB Interfaces	2, USB 2.0
----------------	------------

## B EMC Information

### - Guidance and Manufacture's Declaration

#### B.1 Electromagnetic Emissions

<b>Guidance and manufacture's declaration – electromagnetic emission</b>		
iM3s series are intended for use in the electromagnetic environment specified below. The customer or the user of iM3s series should assure that they are used in such an environment.		
<b>Emission test</b>	<b>Compliance</b>	<b>Electromagnetic environment – guidance</b>
RF emissions CISPR 11	Group 1	iM3s series use RF energy only for their internal function. Therefore, their RF emissions are very low and are not likely to cause any interference in nearby electronic equipment.
RF emission CISPR 11	Class B (Class A: when work with CS-05 Extended Stand)	iM3s series are suitable for use in all establishments, other than domestic establishments and those directly connected to the public low-voltage power supply network that supplies buildings used for domestic purposes.
Harmonic emissions IEC/EN 61000-3-2	Class A	
Voltage fluctuations/ flicker emissions IEC/EN 61000-3-3	Complies	

**NOTE:**

**(When work with CS-05 Extended Stand) The EMISSIONS characteristics of iM3s series make it suitable for use in industrial areas and hospitals (CISPR 11 class A). If it is used in a residential environment (for which CISPR 11 class B is normally**

required) iM3s series might not offer adequate protection to radio-frequency communication services. The user might need to take mitigation measures, such as relocating or re-orienting the equipment.

## B.2 Electromagnetic Immunity

<b>Guidance and manufacture's declaration – electromagnetic immunity</b>			
iM3s series are intended for use in the electromagnetic environment specified below. The customer or the user of iM3s series should assure that they are used in such an environment.			
<b>Immunity test</b>	<b>IEC/EN 60601 test level</b>	<b>Compliance level</b>	<b>Electromagnetic environment - guidance</b>
Electrostatic discharge (ESD) IEC/EN 61000-4-2	$\pm 8$ kV contact $\pm 15$ kV air	$\pm 8$ kV contact $\pm 15$ kV air	Floors should be wood, concrete or ceramic tile. If floor are covered with synthetic material, the relative humidity should be at least 30%.
Electrical fast transient/burst IEC/EN 61000-4-4	$\pm 2$ kV for power supply lines	$\pm 2$ kV for power supply lines	Mains power quality should be that of a typical commercial or hospital environment.
Surge IEC/EN 61000-4-5	$\pm 1$ kV for line to line $\pm 2$ kV for line to ground	$\pm 1$ kV for line to line $\pm 2$ kV for line to ground	Mains power quality should be that of a typical commercial or hospital environment.

<p>Power frequency (50/60 Hz) magnetic field IEC/EN 61000-4-8</p>	<p>30 A/m</p>	<p>30 A/m</p>	<p>Power frequency magnetic fields should be at levels characteristic of a typical location in a typical commercial or hospital environment.</p>
<p>Voltage dips, short interruptions and voltage variations on power supply input lines IEC/EN 61000-4-11</p>	<p>0 % UT; 0.5 cycle At 0°, 45°, 90°, 135°, 180°, 225°, 270° and 315° 0 % UT; 1 cycle and 70 % UT; 25/30 cycles ) Single phase: at 0° 0 % UT; 250/300 cycle</p>	<p>0 % U<sub>T</sub>; 0.5 cycle At 0°, 45°, 90°, 135°, 180°, 225°, 270° and 315° 0 % U<sub>T</sub>; 1 cycle and 70 % U<sub>T</sub>; 25/30 cycles ) Single phase: at 0° 0 % U<sub>T</sub>; 250/300 cycle</p>	<p>Mains power quality should be that of a typical commercial or hospital environment. If the user of iM3s series requires continued operation during power mains interruptions, it is recommended that iM3s series be powered from an uninterruptible power supply or a battery.</p>



IMMUNITY to proximity magnetic fields	Test frequency: 30 KHz; 65 A/m, Modulation: Pulse modulation, 2.1 KHz Test frequency: 134.2 KHz; 7.5 A/m, Modulation: Pulse modulation, 50 KHz Test frequency: 13.56 MHz;	Test frequency: 30 KHz; 65 A/m, Modulation: Pulse modulation, 2.1 KHz Test frequency: 134.2 KHz; 7.5 A/m, Modulation: Pulse modulation, 50 KHz Test frequency: 13.56 MHz;	--
<b>NOTE</b> $U_T$ is the a.c. mains voltage prior to application of the test level.			

### B.3 Electromagnetic Immunity

Guidance and manufacture's declaration – electromagnetic immunity			
iM3s series are intended for use in the electromagnetic environment specified below. The customer or the user of iM3s series should assure that they are used in such an environment.			
Immunity test	IEC/EN 60601 test level	Compliance level	Electromagnetic environment - guidance
Conducted RF	$3 V_{rms}$ 150 kHz to 80	$3 V_{rms}$ 150 kHz to	Portable and mobile RF communications equipment should be used no closer to any part of iM3s series, including cables, than the recommended separation distance calculated from the equation applicable to the frequency of the transmitter.

<p>IEC/EN 61000-4-6 Radiated RF IEC/EN 61000-4-3</p>	<p>MHz 6Vrms<sup>c</sup> in ISM bands between  0.15 MHz and 80 MHz  3 V/m 80 MHz to 2.7 GHz  See table 1</p>	<p>80 MHz 6Vrms<sup>c</sup> in ISM bands between  0.15 MHz and 80 MHz  3 V/m 80 MHz to 2.7 GHz  Comply with table 1</p>	<p><b>Recommended separation distance</b></p> <p><math>d = 1.2\sqrt{P}</math> 150KHz to 80MHz  <math>d = 1.2\sqrt{P}</math> 80 MHz to 800 MHz  <math>d = 2.3\sqrt{P}</math> 800 MHz to 2.7 GHz  <math>d = 6 \sqrt{P} / E</math> at RF wireless communications equipment bands (Portable RF communications equipment (including peripherals such as antenna cables and external antennas) should be used no closer than 30 cm (12 inches) to any part of the iM3s series, including cables specified by the manufacturer).</p> <p>Where P is the maximum output power rating of the transmitter in watts (W) according to the transmitter manufacturer and d is the recommended separation distance in meters (m).</p> <p>Field strengths from fixed RF transmitters, as determined by an electromagnetic site survey,<sup>a</sup> should be less than the compliance level in each frequency range.<sup>b</sup></p> <p>Interference may occur in the vicinity of equipment marked with the following symbol:</p>
--	--	---	--



**NOTE 1** At 80 MHz and 800 MHz, the higher frequency range applies.

**NOTE 2** These guidelines may not apply in all situations. Electromagnetic propagation is affected by absorption and reflection from structures, objects and people.

- <sup>a</sup> Field strengths from fixed transmitters, such as base stations for radio (cellular/cordless) telephones and land mobile radios, amateur radio, AM and FM radio broadcast and TV broadcast cannot be predicted theoretically with accuracy. To assess the electromagnetic environment due to fixed RF transmitters, an electromagnetic site survey should be considered. If the measured field strength in the location in which iM3s series are used exceeds the applicable RF compliance level above, iM3s series should be observed to verify normal operation. If abnormal performance is observed, additional measures may be necessary, such as reorienting or relocating iM3s series.
- <sup>b</sup> Over the frequency range 150kHz to 80MHz, field strengths should be less than 3V/m.
- <sup>c</sup> The ISM (industrial, scientific and medical) bands between 0.15 MHz and 80 MHz are 6.765 MHz to 6.795 MHz; 13.553 MHz to 13.567 MHz; 26.957 MHz to 27.283 MHz; and 40.66 MHz to 40.70 MHz. The amateur radio bands between 0.15 MHz and 80 MHz are 1.8 MHz to 2.0 MHz, 3.5 MHz to 4.0 MHz, 5.3 MHz to 5.4 MHz, 7 MHz to 7.3 MHz, 10.1 MHz to 10.15 MHz, 14 MHz to 14.2 MHz, 18.07 MHz to 18.17 MHz, 21.0 MHz to 21.4 MHz, 24.89 MHz to 24.99 MHz, 28.0 MHz to 29.7 MHz and 50.0 MHz to 54.0 MHz.

**Table 1 Test specifications for ENCLOSURE PORT IMMUNITY to RF wireless communications equipment**

Test frequency (MHz)	Band <sup>a)</sup> (MHz)	Service <sup>a)</sup>	Modulation <sup>b)</sup>	Maximum power (W)	Distance (m)	Immunity test level (V/m)
385	380-390	TETRA 400	Pulse modulation <sup>b)</sup> 18 Hz	1.8	0.3	27
450	430-470	GMRS 460, FRS 460	FM <sup>c)</sup> ± 5 kHz deviation 1 kHz sine	2	0.3	28
710	704-787	LTE Band 13, 17	Pulse modulation <sup>b)</sup> 217 Hz	0.2	0.3	9
745						
780						
810	800-960	GSM 800/900, TETRA 800, iDEN 820, CDMA 850, LTE Band 5	Pulse modulation <sup>b)</sup> 18 Hz	2	0.3	28
870						
930						
1720	1700-1990	GSM 1800; CDMA 1900; GSM 1900; DECT; LTE Band 1, 3, 4, 25; UMTS	Pulse modulation <sup>b)</sup> 217 Hz	2	0.3	28
1845						
1970						

2450	2400-2 570	Bluetooth, WLAN, 802.11 b/g/n, RFID 2450, LTE Band 7	Pulse modulation <sup>b)</sup> 217 Hz	2	0.3	28
5240	5100-5	WLAN	Pulse	0.2	0.3	9
5500	800	802.11	modulation <sup>b)</sup>			
5785		a/n	217 Hz			

**NOTE** If necessary to achieve the IMMUNITY TEST LEVEL, the distance between the transmitting antenna and the ME EQUIPMENT or ME SYSTEM may be reduced to 1 m. The 1 m test distance is permitted by IEC 61000-4-3.

a) For some services, only the uplink frequencies are included.

b) The carrier shall be modulated using a 50 % duty cycle square wave signal.

c) As an alternative to FM modulation, 50 % pulse modulation at 18 Hz may be used because while it does not represent actual modulation, it would be worst case.

## B.4 Recommended Separation Distances

<b>Recommended separation distances between portable and mobile RF communications equipment and iM3s series</b>			
iM3s series are intended for use in an electromagnetic environment in which radiated RF disturbances are controlled. The customer or the user of iM3s series can help prevent electromagnetic interference by maintaining a minimum distance between portable and mobile RF communications equipment (transmitters) and iM3s series as recommended below, according to the maximum output power of the communications equipment.			
Rated maximum output power of transmitter  (W)	Separation distance according to frequency of transmitter(m)		
	150 kHz to 80 MHz  $d = 1.2\sqrt{P}$	80 MHz to 800 MHz  $d = 1.2\sqrt{P}$	800 MHz to 2.7 GHz  $d = 2.3\sqrt{P}$
0.01	0.12	0.12	0.23
0.1	0.38	0.38	0.73
1	1.2	1.2	2.3
10	3.8	3.8	7.3
100	12	12	23
For transmitters rated at a maximum output power not listed above, the recommended separation distance $d$ in meters (m) can be estimated using the equation applicable to the frequency of the transmitter, where $P$ is the maximum output power rating of the transmitter in watts (W) according to the transmitter manufacturer.			
<b>NOTE 1</b> At 80 MHz and 800 MHz, the separation distance for the higher frequency range applies.			
<b>NOTE 2</b> These guidelines may not apply in all situations. Electromagnetic propagation is affected by absorption and reflection from structures, objects and people.			

## C Default Settings

This appendix documents the most important default settings of your monitor as it is delivered from the factory.

**Note:** If your monitor has been preconfigured according to your requirements, the settings at delivery will be different from the default settings listed here.

### C.1 Patient Information Default Settings

Patient Information Settings		
Patient Type	Adult	
The start and end code of patient barcode		
Contents	Start code	End code
MRN	1	12
Family Name	0	0
Given Name	0	0
Gender	0	/
Birth Year	0	0
Birth Month	0	0
Birthday	0	0
Gender code of patient barcode		
Male	0	
Female	1	

### C.2 Operator Information Default Settings

The start and end code of operator barcode		
Contents	Start code	End code
ID	1	12
Family Name	0	0
Given Name	0	0

### C.3 SpO<sub>2</sub> Default Settings

SpO <sub>2</sub> Settings	
Pitch Tone	On
Sensitivity	Medium
Sweep	6.25 mm/s

### C.4 PR Default Settings

PR Settings	
PR Source	SpO <sub>2</sub>
Pulse Volume	Medium

### C.5 NIBP Default Settings

NIBP Settings	ADU	PED	NEO
Inflation value	160	140	100
Unit	mmHg		
Interval (Average)	1 minute		
Measurement times (Average)	3		

### C.6 TEMP Default Settings

TEMP Settings	
Unit	°C
F3000 TEMP	
Measurement Mode	Predictive
Measurement Position	Oral
Low Temp. Mode	Off



## D Abbreviations

Abbr	English Full Name/Description
AC	Alternating current
Adu	Adult
Art	Arterial
BP	Blood pressure
BTPS	Body temperature and pressure, saturated
CI	Cardiac index
CISPR	International Special Committee on Radio Interference
COHb	Carboxyhemoglobin
DC	Direct current
Dia	Diastolic
DoS	Denial of Service
DDoS	Distributed Denial of Service
EEC	European Economic Community
EMC	Electromagnetic compatibility
EMI	Electromagnetic interference
ESU	Electrosurgical unit
FCC	Federal Communication Commission
FDA	Food and Drug Administration
Hb	Hemoglobin
Hb-CO	Carbon mono-xide hemoglobin
HR	Heart rate
ICU	Intensive care unit
ID	Identification
IEC	International Electrotechnical Commission
IEEE	Institute of Electrical and Electronic Engineers
LCD	Liquid crystal display
LED	Light emitting diode

Abbr	English Full Name/Description
MAP	Mean arterial pressure
MDD	Medical Device Directive
MetHb	Methemoglobin
MRI	Magnetic resonance imaging
N/A	Not applied
Neo	Neonate
NIBP	Non-invasive blood pressure
O <sub>2</sub>	Oxygen
OxyCRG	Oxygen cardio-respirogram
Ped	Pediatric
Pleth	Plethysmogram
PR	Pulse rate
PVC	Premature ventricular complex
R	Right
RA	Right arm
RAP	Right atrial pressure
RHb	Reduced hemoglobin
RL	Right leg
RR	Respiration Rate
Sev	Sevoflurane
SYS	Systolic pressure
SpO <sub>2</sub>	Pulse Oxygen Saturation
TB	Blood Temperature
TD	Temperature difference
TEMP	Temperature
USB	Universal serial bus

P/N: 01.54.458691

MPN: 01.54.458691016



EDAN INSTRUMENTS, INC.

#15 Jinhui Road, Jinsha Community, Kengzi Sub-District

Pingshan District, 518122 Shenzhen, P.R.China

Email: [info@edan.com](mailto:info@edan.com)

TEL: +86-755-2689 8326 FAX: +86-755-2689 8330

Website: [www.edan.com](http://www.edan.com)



EC REPRESENTATIVE

Shanghai International Holding Corp. GmbH

Eiffestrasse 80, 20537 Hamburg Germany

TEL: +49-40-2513175

E-mail: [shholding@hotmail.com](mailto:shholding@hotmail.com)